

Multiplexer for automatic testing of multimedia units

Karel Rendl¹, Tomas Blecha¹, Ladislav Herc², Lukas Klocker², Richard Linhart¹, Petr Sehnal²,
Frantisek Steiner¹, Vaclav Wirth¹

¹University of West Bohemia

Univerzitni 8, 306 14 Pilsen, Czech Republic

²Continental Automotive Czech Republic s.r.o.

Průmyslová 1851, 250 01 Brandýs nad Labem – Stará Boleslav, Czech Republic

E-mail : krendl@ket.zcu.cz

ABSTRACT:

This article deals with automatic testing of multimedia units. The aim of the work was to design and implement an automatic test system for a functional parameter measurement of multimedia units. The system was built up with the help of individual measuring devices and the designed multiplexer. The multiplexer functions are described in detail. The entire system is controlled by the control computer. For the control computer it was necessary to create software to control with devices and multimedia unit and communicate with them. For creating utility programs, the Labview programming language and Teststand software tool from National Instruments were chosen.

INTRODUCTION

This article deals with possibilities of the automatic testing of multimedia units. The cooperation between the University of West Bohemia and Continental Automotive Czech Republic Ltd. enabled the system realization. The company will continue to use this system. In order to find out whether a tested product is in accordance with required parameters, the testing includes the measurement of multimedia unit parameters. These parameters are given by a customer and its fulfillment warrants a correct functionality and a service life of a product. Formerly, the test was carried out manually according to single measurements. The manual test was time-consuming therefore a demand for automatic tester making occurred.

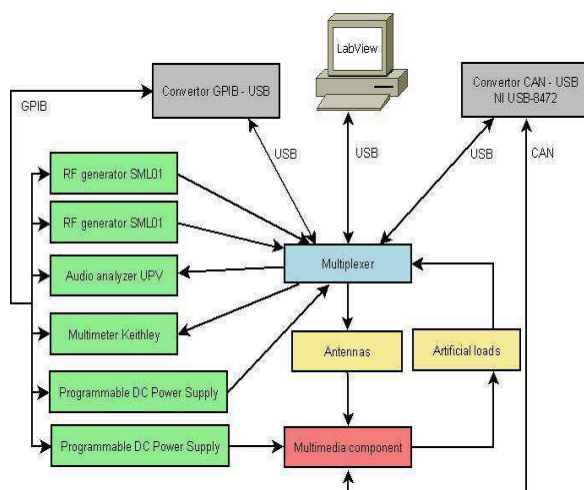

Fig. 1. Flow diagram of the test system.

This article describes the measuring system enabling a measurement of basic functional parameters and the used software and hardware which enable further modification for other parameter tests. The flow

diagram of the testing system is seen in the fig. 1. Since currently all devices are not used at once, they are connected by the help of the multiplexer. The multiplexer is controlled by a control computer. In dependence on a type of procedure measurement, individual measuring devices are connected to outputs of a multimedia unit.

HARDWARE SOLUTION

Basic measuring set consists of the following discrete measuring devices. For DC power supply, there are two programmable sources. The actual test set consists of two RF generators, multimeter and audio analyzer. In order to test the performance parameters, the system is supplemented by artificial loads and antennas. The correct connection of multimedia units, loads, sources, and measuring instruments is controlled by the multiplexer. Connection of individual devices might differ for each measured parameter.

Interconnections

All the above-mentioned measuring devices allow connections via GPIB interface. Therefore, this interface was selected for device control and data transmission. GPIB is one of the best buses specifically designed for applications which control measuring devices or other devices. It is a robust communication bus, which belongs to the most widely used buses for control devices. These interfaces are characterized by low latency and acceptable bit rate. Transmission of messages over the GPIB interface is often in the form of ASCII characters [1]. With this bus, it is possible to connect multiple devices to a total bus length of 20 m.

Multimedia unit uses the CAN interface for communication. Multimedia unit for this interface

can also be controlled. The use of CAN is adapted to use in the automotive industry. Multimedia units communicate using CAN low-speed or high-speed CAN. The tester can be used for both options. The exchange requires no intervention into the control software.

For the connection between the multiplexer and control computer, USB was used. USB has recently become a popular interface for connecting peripheral devices to a computer. It also applies in test and measurement industries. This makes possible to use a standard office computer for control. This interface is also used for connecting CAN and GPIB bus converters. It is used USB-GPIB and USB-CAN converters from National Instruments. This manufacturer was chosen for ease of use of converters in Labview programming environment. The entire test system is connected to the control computer by the only one USB line. It is connected to the multiplexer in which converters are connected.

Multiplexer was designed to ensure a correct connection during an individual-parameter measurement. Further, it enables to communicate between a control computer and operated units. Multiplexer is connected to the control computer only by the USB interface. Currently, the USB interface is the most often used device for connection with the control computer. Due this fact, it is possible to use a personal computer for controlling. All measuring devices are connected by the help of GPIB bus. This bus is one of the most tested ones which is designed for applications which can control measuring devices. It is a robust communication bus which is among the most popular and the most used buses for device control. The converter from NI company is used for conversions from GPIB to USB. The communication with a multimedia unit proceeds through the CAN bus. Its design and subsequent use are adjusted for exploitation in automotive industry. For conversion from CAN to USB, the convertor from NI company (USB – 8472) was used again. No drivers for communication with a multimedia unit are given by the producer. Therefore it was necessary to make them in Labview. Created programs for individual devices were used in automated test sequence.

Multiplexer is designed as a modular device which is composed of individual and interconnected cards. Modular system enables a future extension according to testing requests. Presently, the system is composed of five cards. The function of each individual card is described below.

Communication and control unit

The communication and control unit acts as a central node of the measurement circuit switching box. It has two functionalities, the USB interface HUB and microcontroller (MPU) for driving other units installed in the circuit switching box. The USB hub allows covering multiple communication interfaces

with a single USB connection to the control PC. All input and output signals are fed via a standard DIN41612 connector. There are seven output ports on the HUB. Four ports are used in the unit internally, next three ports are fed to standard USB-A connectors and used for external interfaces. The unit contains three internal interfaces, the RS232, 5V UART and 3.3V UART, called gateways. Additional 3.3V UART interface is used for microcontroller. In the block diagram of the unit, fig. 2, there are examples of three external interfaces. You can see a high speed and a low speed CAN and the GPIB interface there.

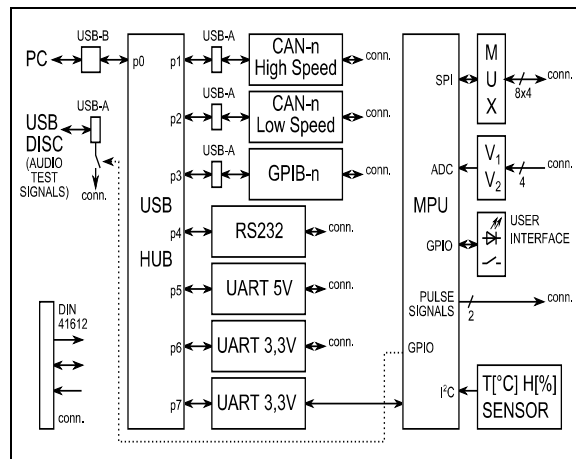

Fig. 2: Communication and control unit

Microcontroller acts as a command interpreter for driving all another units in the circuit switching box. All the units are connected by the eight fast serial SPI buses, where the signal is distributed using a special interface (MUX). For lower EMC radiation, and better load distribution, the SPI signals are sent only to one bus during one transmission. Better reliability is achieved by circular connection of all buses and read back the data sent. All transmissions are periodically repeated and possible errors are indicated. The simple user interface equipped with basic functionalities is added for better comfort for a user. Environmental parameters, which are often monitored during a test procedure, can be automatically collected by a built in temperature and humidity sensor. The unit is equipped with two special pulse signal outputs and four voltage monitoring inputs. The pulse signals could be used for simulation of control signals (1ms pulses ... commands for DUT) or periodical signals with frequency related to vehicle speed for example. Voltage monitoring inputs could be used for status sensing of fuses, etc... The last feature allows connection or disconnection of USB FLASH disc to DUT USB interface in dependence on command from MPU. This is required part of some test procedures.

Switching and load unit

The switching and load unit produces eight user definable signals (TP0..7), for testing simple parallel input and output interfaces of DUT. In default state, all eight signals are in high impedance. Regarding to commands received via SPI bus by the SPI receiver (SPI RX), every of the signals could be switched to Vbat or GND. This task is provided by two packs of relays, Re0..7a and Re0..7b. The circuit could be equipped with load resistors RH0..7 and RL0..7, and then the circuit can act as an artificial load connected to the Vbat or GND. The current through main relays could be monitored using a current sense amplifier and RSC1..8, when one of the relays is switched on. Also, the voltage on every signal wire could be monitored, if the voltage before or after load connection is necessary to know. All measurement points are connected to one measurement output (MEAS OUT) using another two packs of relays (Re0..7c and Re0..7d). All relays are driven via delay circuits (DELAY), so switching on is delayed 20 ms, and switching off is not delayed. These delay circuits will help a short circuit connection, when relay state changes. Main relays to Vbat and GND are also connected in exclusivity (EXCL), so it cannot be activated together to a short circuit. Measurement relays are driven via decoder 1/8, because of no activation more than one of them. The main relays must withstand 5 A of load current. In addition, there is a test serial resistors R_s bypassed by a relay, so it is possible to test the DUT connection on a weak Vbat and GND.

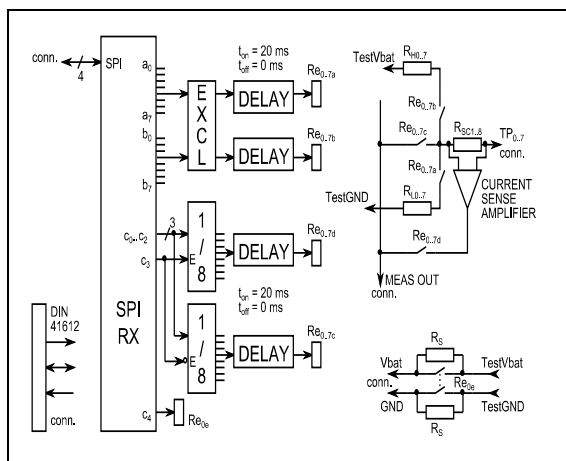

Fig. 3: Switching and load unit

The block circuit diagram of the switching and load unit is in fig. 3. On the left, there is a SPI receiver and control logic, on right up is a simplified connection of one of eight test signal circuits, right down is circuit of test serial resistors.

Power, pulse signals, resistance signals and measurement unit

This unit is combination of two channel power supply, two channel interface for pulse signals, two channel interface for resistance signals and a voltage measurement switch. The power supply acts as a two channel, SPI controlled switch which could be used to feed two independent DUT circuits. Each channel has an output voltage (VM1, VM2) and current (CM1, CM2) measurement. The current is sensed in two ranges, one big (5A) for normal operation mode of DUT and one small (100mA) for standby mode of DUT. Pulse signals generated in control unit are electrically shifted by a FET switches. One signal is referred to GND, one to Vbat. In off state, the voltage on both channels could be measured. Resistance signals are used to simulate a resistor-coded keyboard or similar device. Up to eight resistance steps in each channels could be selected via SPI bus. In each state, the output voltage could be measured. Additionally, the unit is equipped with a SPI bus controlled eight channel relay switch (Re0..7b), which will connect voltage measurement outputs of another units into one multimeter. All voltages measured inside this unit are switched into the same central point via relays Re0..7a and then do not need any of eight measurement inputs noted above.

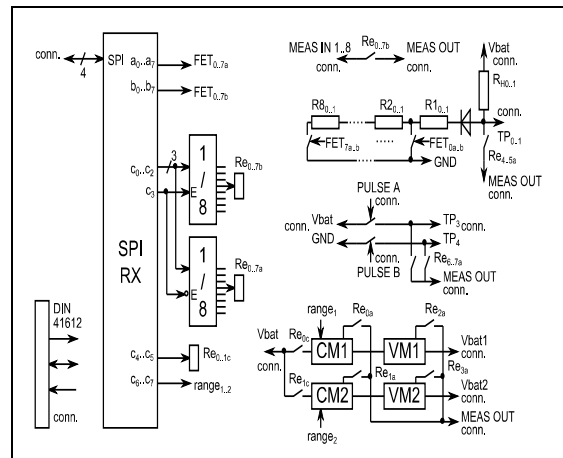

Fig. 4: Power, pulse signals, resistance signals and measurement unit

Audio signal unit

The main parts of audio signal unit are four dummy loads (L) for DUT power amplifier testing. These loads consist of high power resistors (up to 20 W) and optional serial inductance. Because of possible bridge configuration of power amplifiers, the connection of all loads is balanced. Signal on each load is sensed by an audio analyzer Rohde&Schwarz UPL input. There is also possible to sense four line inputs (without load) in balanced connection too. The analyzer inputs

are switched to all line or load signals using SPI controlled signal relays. If the unbalanced connection will be needed, the configuration change will be made inside UPL. Also, the load impedance for every line input signal could be changed this way. Second part of unit allows connect UPL generator output to four output ports which can be used for driving auxiliary or microphone inputs of DUT. The balanced circuit connection is kept here too, because some DUT's microphone inputs requiring it. If the unbalanced connection will be needed, the configuration change will be made inside UPL. Also, the source impedance for every signal could be changed this way.

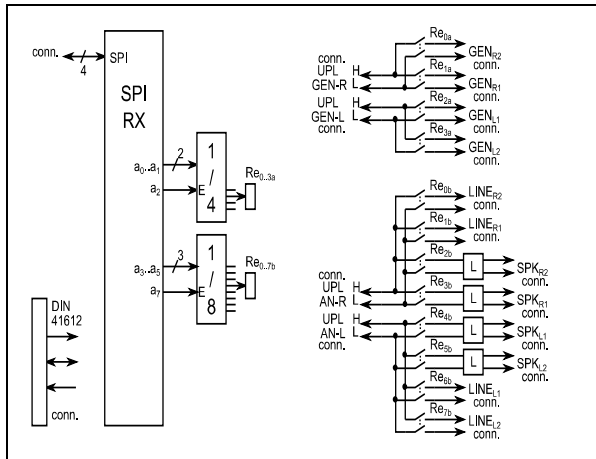

Fig. 5: Audio signal unit

Radio frequency unit

The radio frequency unit is intended for testing of radio receiver (tuner) inputs of DUT. The main part of unit is called universal splitter (fig. 6 right up). It consists of five high frequency FET switches controlled via SPI interface. These switches have a non reflecting internal connection, so all unused branches in switch are terminated internally. Using the universal splitter, DUT tuners can be tested in four modes:

- 1) Direct - generator 1 connected to tuner1, generator 2 to tuner 2.
- 2) Splitter – generator 1 connected to both tuners, generator 2 terminated.
- 3) Join to 1 – signal from generator 1 and generator 2 mixed and fed to tuner 1, tuner 2 terminated.
- 4) Join to 2 – signal from generator 1 and generator 2 mixed and fed to tuner 2, tuner 1 terminated.

Additionally, the unit contains four general purpose high frequency two-way switches controlled via SPI bus. All high frequency signals are fed through a DIN 41612 connector equipped with shielded high frequency pins. Last blocks called DRIVER are general purpose high current SPI controlled outputs.

These 2 x 8 signals could be used for driving two external relay step signal attenuators.

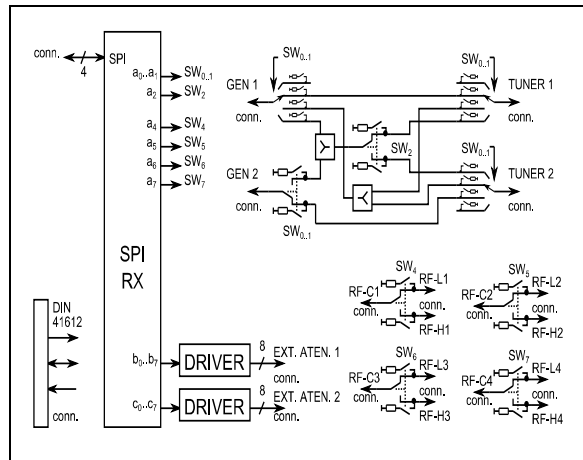
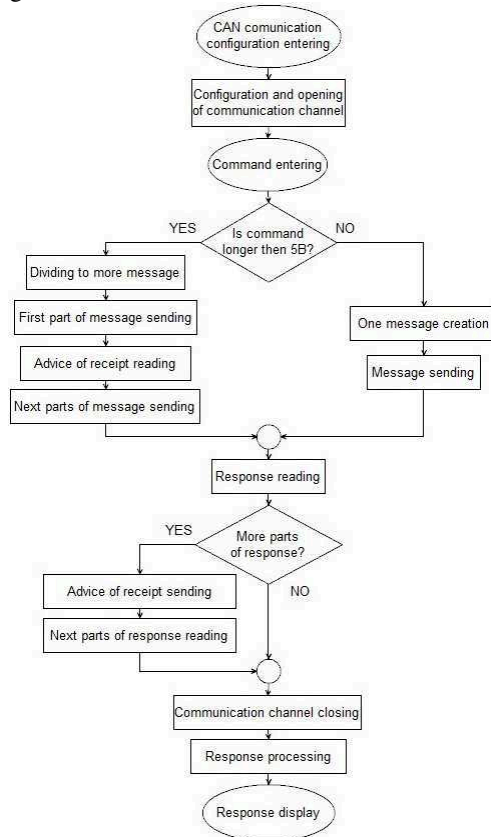

Fig. 6: Radio frequency unit

SOFTWARE SOLUTION

Labview programming environment from National Instruments was used to create the control software. It is a graphical programming environment that is suitable for use in measurement and testing. All used measuring devices have a support from the manufacturer in terms of drivers for Labview. This reduces the needed time for a functional applications writing.



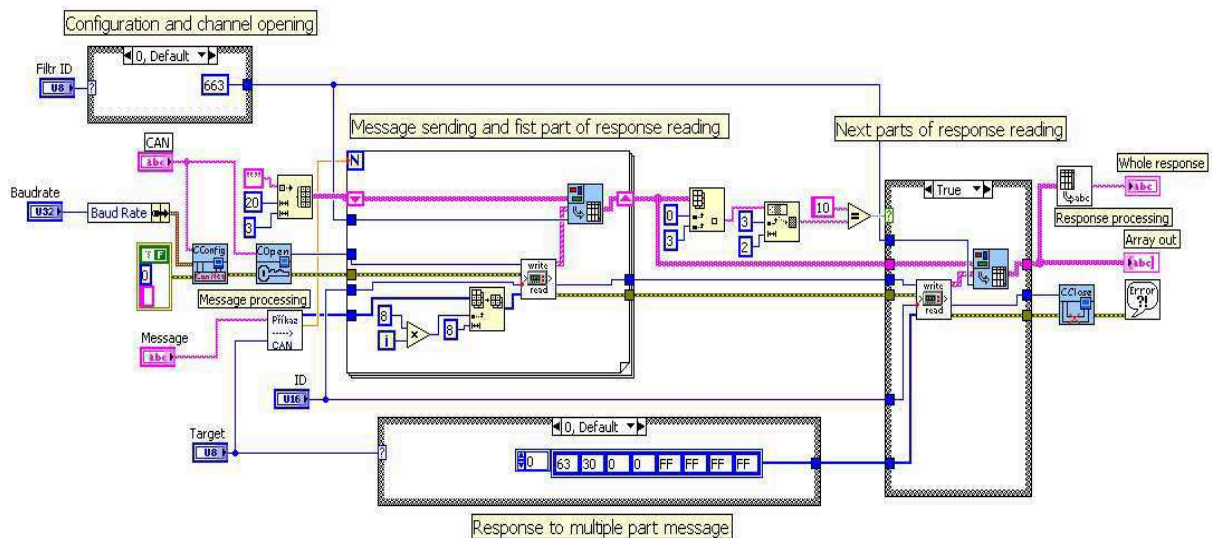

Fig. 8. CAN communication with multimedia unit.

Fig. 7. Flowchart of the CAN communication.

Controlling programs for all measuring devices were created in Labview. Furthermore, a program for communication with the media unit for the CAN interface was made. Flowchart of communication with the multimedia unit is shown in Figure 7. [3] The program starts with configuration and the CAN channel opening, after which the communication is carried out. It is also necessary to create a command for DUT controlling according to supplied specifications. After configuration, the channel setup and a command for DUT, the loop for an order sending and following DUT response readout for a given order follow. Obtained answer should be consequently processed. As it is sent in parts therefore it is filtered and the composition of the parts is carried out. According to specification, it is possible to transfer 5 bytes of data by using a single framework in this case of the order. The order that is longer must be divided into several parts and sent divided. After receiving the first part of the message, it must be detected that it is a multiple transfer and confirmation of the first part receive must be sent. Then, the following sections are sent. Communication in the opposite direction (replies of multimedia unit) works in the same way. After reading out the data, it is necessary to stop the bus communication and close by using the function close. Block diagram of Labview program is shown in Figure 8. [4]

Individual programs for communication with the measuring devices and multimedia units are used in test sequences. In order to create this sequence, Teststand software was used. This is the software from National Instruments that is used for design and operation of automated tests. Setting of the measuring devices can be modified directly in the sequence by the help of the input parameters for individual programs. Each sequence consists of programs for the

set of all required parts of the test system, programs loads and data processing. Teststand allows you to evaluate the tested parameters of the multimedia unit and evaluates all parts of the test as satisfactory or unsatisfactory. For each test, a report is processed. For each part of sequence of measured values, it contains a statement if the required parameters are met.

CONCLUSION

The automatic test system for multimedia units testing was created. Further, the software for communication with the measuring devices and multimedia unit was made. For this system, multiplexer was designed and then consequently implemented to test multimedia units. This enables an interconnection of measuring devices, multimedia units and a control computer. Multiplexer is designed for current requirements for functional parameters measurement, but these requirements might be extent according to actual customer demands in the future. The advantage of the multiplexer that we designed is particularly its modular setup which is possible consequently extent. Multiplexer is a part of the automatic testing system that was made for this purpose. For system control, a control computer with Labview and Teststand systems are used. It controls testing sequences and also communication with a multimedia unit. It is possible to expand extend to include other measuring devices. It enables to test more parameters for different types of multimedia units. Afterwards, it is necessary to program the control program for a new device and carry out the modification of a test sequence. Complete automation of the test made by the designed system halves the time that is necessary for testing and significantly decreased demands for operation.

ACKNOWLEDGMENTS

The paper is part report and has been supported by the research plan of Ministry of Industry and Trade no. FR-TI3/497 “Multimedia units – new test and analytical methods development intended for product development with high quality and high manufacturing grade” and by the research plan of Ministry of Education, Youth and Sports of Czech Republic no. CZ.1.0.5/2.1.00/03.094 “Regional Innovation Center for Electrical Engineering (RICE)”.

LITERATURA

- [1] ROHDE SCHWARZ GMBH. UPV Audio Analyzer: User manual. Munich, Germany, 2011. Available: http://www2.rohde-schwarz.com/file_2551/UPV_User_Manual_e.pdf
- [2] ČSN EN 60315-4. Methods of measurement on radio receivers for various classes of emission: Část 4: Receivers for frequency-modulated sound broadcasting emissions. ČNI, 1999.
- [3] VLACH, Jaroslav, Josef HAVLICEK and Martin VLACH. Zaciname s LabVIEW. 1. vyd. Praha: BEN, 2008. ISBN 978-80-7300-245-9.
- [4] NATIONAL INSTRUMENTS. CAN: NI-CAN Hardware and Software Manual. Austin, Texas, 2010. Available: <http://www.ni.com/pdf/manuals/370289n.pdf>.
- [5] NATIONAL INSTRUMENTS. Software-Defined Test Fundamentals. Austin, Texas, 2009. Available: http://download.ni.com/evaluation/ate/software_defined_test_fundamentals_guide.pdf.