

Dynamical analysis of machining tool body with reinforced inner core of circular shape

M. Nad' ^{a,*}

^a Faculty of Materials Science and Technology in Trnava, Slovak University of Technology, Paulínska 16, 917 24 Trnava, Slovak Republic

Received 29 September 2008; received in revised form 15 April 2009

Abstract

The vibration analysis of a clamped beam structure representing vibrating machining body tool is solved in this paper. The required modal properties of beam are obtained by application the reinforcing core with circular cross section. The perfect adhesion between core material and basic beam material is considered. The different material properties of beam and core are considered. The fundamental mathematical formulations describing the bending vibrations of this composite beam structure are presented. The effect of material properties and geometrical parameters of reinforcing core on natural frequencies of cantilever composite beam structure with circular and rectangular cross section is presented. This form of composite beam structure provides effective tool to modification of its dynamical properties.

© 2009 University of West Bohemia. All rights reserved.

Keywords: machining tool, beam, reinforcing core, structural modification, bending vibration

1. Introduction

The requirements on design and production of the structures, machines and tools with higher performance, material and economical effectivity have been increased in the recent years. The performance growth is mostly achieved by increasing of operating velocities and cycles. The requirements on material effectiveness during design process tend to the constructions with decreasing stiffness. All these changes affect the dynamical properties. Consequently, the structures are often loaded by external dynamical periodic loads producing undesirable dynamic effects which very often induce resonant vibrations.

The beam structure can be considered as one of the most important structural elements, which is very often used in machines and constructions. Moreover, many of the machining tools (e.g. lathe tools, boring tools, a.o.) have the shapes corresponding to beam structures and they are representative structures similar to cantilever beam. During the machining process, the tools are subjected to the several exciting effects [1, 4]. The cutting velocities and forces, chip creation processes, stiffness of the system MTW (Machine-Tool-Workpiece) are the most significant effects influencing on the dynamics of MTW system as well as machining process (roughness of machined surface, tool wear, damage of tool or workpiece, noise level a.o.). It can be expected that the tools are the most critical members of the MTW system [8, 10]. The most serious problems occur when the frequency of periodical change some of the significant effects of machining process is near to some of the natural frequencies of machining tool — the resonant state appears. The resonant state has deteriorating effect on functionality of the

*Corresponding author. Tel.: +421 335 511 006 ext. 32, e-mail: milan.nad@stuba.sk.

machining tool as well as on the quality of machining process [6, 7]. The dynamical properties of machining tool (considered as a cantilever beam structure) such as natural frequencies and mode shapes are dependent on geometrical parameters and material properties. The machining tool bodies are normally made of homogeneous materials, but very often the requirements to change the dynamical properties by some technological or design treatments of machining tool body and requirements to eliminate inconvenient dynamical effects are occurred.

The manner of creation of the body tool presented in this paper is focused on obtaining of the required dynamical properties of the beam structure by embedding the reinforcing core into beam. The technique of the modification of dynamic properties of this beam composite structure is based on changes of material properties and dimensions of beam core. The arrangement of the beam structure makes it possible to create a light-weight structure consisting from closed outer profile (load supporting part of the profile) with inner space of the profile filled by material of lower rigidity (e.g. aluminium foam). Contrary, the core can be used as reinforcing part of composite profile, i.e. the core is load supporting part of the profile.

To the best author's knowledge, no analysis of the similar beam structure, presented in this paper, is available in literature on design of machining tool bodies. It has to be noted, that in accordance with the expected requirements, also other structures can be created, which are based on the layered structures — sandwich or laminated beams. However, in many cases, the applications of the layered structures to the machining tool bodies can have design as well as technological restrictions, e.g achieving the required dynamical properties of layered beam structure mainly for uniaxial loading effect, delamination, chemical instability of the material layers subjected to contact with coolant a.o.

In this paper, the natural frequency characteristics of cantilever beam structure (as a model of machining toll body) for various diameters and material properties of core are obtained. The sensitivity of individual parameters is assessed from the change of the natural frequency of cantilever beam with circular cross section of reinforcing core.

2. Formulation of the problem

In this paper the cantilever beams with uniform circular and rectangular cross sections are analysed. The cross section of beam consists of a basic shape of profile (circle or rectangle) and centred reinforcing core with uniform circular cross section (see Fig. 1).

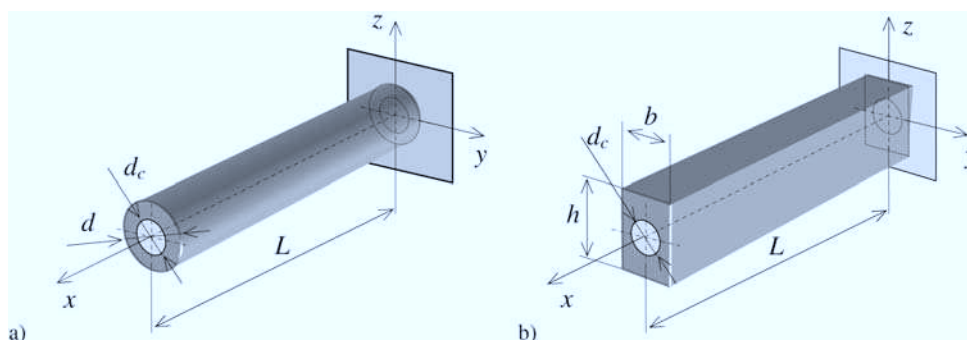

Fig. 1. The models of beam with circular uniform cross section of reinforcing core

2.1. Theoretical description of computational model

The mathematical formulation of free bending vibration of Euler-Bernoulli beam with homogeneous uniform cross section is described by well-known partial differential equation of 4th order [9], i.e.

$$\rho S \frac{\partial^2 w(x, t)}{\partial t^2} + EJ \frac{\partial^4 w(x, t)}{\partial x^4} = 0, \quad (1)$$

where ρ – density of beam material,
 S – area of beam cross section,
 EJ – flexural rigidity of beam,
 E – Young modulus of beam material,
 J – inertia moment of beam cross section,
 $w(x, t)$ – beam deflection in plane xz .

The solution of equation (1) is supposed in the form

$$w(x, t) = W(x)e^{i\omega t}. \quad (2)$$

Next, we introduce non-dimensional parameters

$$\bar{W}(\xi) = \frac{W(x)}{L}, \quad \xi = \frac{x}{L}. \quad (3)$$

Using equations (2) and (3), the equation of motion (1) is transformed into equation

$$\bar{W}^{IV}(\xi) - \beta^4 \bar{W}(\xi) = 0, \quad (4)$$

where $\bar{W}^{IV}(\xi) = \frac{d^4 \bar{W}(\xi)}{d\xi^4}$ and $\beta = \sqrt[4]{\omega^2 L \frac{\rho S}{EJ}}$ – eigenvalue.

The solution of (4) has the form [5]

$$\bar{W}(\xi) = A \sin \beta \xi + B \cos \beta \xi + C \sinh \beta \xi + D \cosh \beta \xi. \quad (5)$$

The boundary conditions for cantilever beam are expressed by following equations

$$\bar{W}(0) = \bar{W}'(0) = \bar{W}''(1) = \bar{W}'''(1) = 0. \quad (6)$$

Then by introducing the solution (5) into boundary conditions (6), the frequency equation and the first four roots following from this equation are

$$1 + \cos \beta \cosh \beta = 0 \Rightarrow \beta_1 = 1,875 1, \quad \beta_2 = 4,694 1, \quad \beta_3 = 7,854 8, \quad \beta_4 = 10,995 5 \quad (7)$$

For given geometrical parameters and material properties, the natural angular frequencies are calculated from equation

$$\omega_i = \left(\frac{\beta_i}{L} \right)^2 \sqrt{\frac{EJ}{\rho S}}. \quad (8)$$

Next, we consider the cantilever beam with uniform cross section of basic profile having reinforcing core with uniform circular cross section. The term “reinforcing” is not quite correct, because the effect of reinforcement by core is generated only for such cases when the material properties of core are characterized by higher rigidity than rigidity of the basic material of beam.

The following assumptions are expected for mathematical modelling of beam with core: core of beam is located symmetrically along reference axis; cross section of beam is perpendicular to the reference axis x and planar before and during deformation; material properties of individual parts of beam are isotropic and homogeneous; perfect adhesion on the interface between beam and core.

The equation of motion of beam modified by core under formulated assumptions can be expressed in the form [3]

$$[\rho S + (\rho - \rho_c)S_c] \frac{\partial^2 w(x, t)}{\partial t^2} + [EJ + (E - E_c)J_c] \frac{\partial^4 w(x, t)}{\partial x^4} = 0, \quad (9)$$

where ρ_c is density of core material, S_c is area of core cross section, E_c is Young modulus of core material, J_c is inertia moment of core cross section.

Using equations (2) and (3) into equation (9), the following equation are obtained

$$\bar{W}_m^{IV}(\xi) - \beta^4 \bar{W}_m(\xi) = 0, \quad (10)$$

$$\beta^4 = \omega_m^2 L \frac{\rho S(1 + \Delta_{\rho S})}{EJ(1 + \Delta_{EJ})}, \quad (11)$$

where

– parameter of mass modification $\Delta_{\rho S} = (\kappa_\rho - 1)\kappa_S, \quad (12)$

– parameter of flexural rigidity modification $\Delta_{EJ} = (\kappa_E - 1)\kappa_J, \quad (13)$

– ratio of densities $\kappa_\rho = \frac{\rho_c}{\rho}, \quad (14)$

– ratio of Young's modulus $\kappa_E = \frac{E_c}{E}, \quad (15)$

– ratio of cross sections $\kappa_S = \frac{S_c}{S}, \quad (16)$

– ratio of inertia moments of cross sections $\kappa_J = \frac{J_c}{J}, \quad (17)$

– ratio of dominant dimensions of cross sections (see Fig. 1, beam with circular cross section $D = d$; beam with rectangular cross section $D = h$)

$$\kappa_d = \frac{d_c}{D}. \quad (18)$$

The natural angular frequency can be expressed from equation (11) in the form

$$\omega_{m,i} = \left(\frac{\beta_i}{L}\right)^2 \sqrt{\frac{EJ(1 + \Delta_{EJ})}{\rho S(1 + \Delta_{\rho S})}} = \omega_i \sqrt{\frac{1 + \Delta_{EJ}}{1 + \Delta_{\rho S}}}. \quad (19)$$

From this follows that the effect of core properties on natural frequencies of beam with core can be expressed by modification function

$$f_m(\Delta_{\rho S}, \Delta_{EJ}) = \frac{\omega_{m,i}}{\omega_i} = \sqrt{\frac{1 + \Delta_{EJ}}{1 + \Delta_{\rho S}}}, \quad (20)$$

where ω_i – natural angular frequency of beam without reinforcing core,
 $\omega_{m,i}$ – modified natural angular frequency of beam with reinforcing core.

The modification function f_m represents shift of the values of natural frequencies caused by changes of core parameters — material density, diameter, Young modulus. From relation (20) can be seen that the modification function is identical for all natural angular frequencies, i.e. the value of i^{th} natural angular frequency of modified beam structure is expressed as a product of the value of i^{th} natural angular frequency of original (unmodified) beam structure and modification function f_m .

2.2. Sensitivity analysis

Using the sensitivity analysis, the influence of changes of independent variables on the analysed function can be investigated. Generally, the sensitivity, represented by partial derivatives, denotes the influence of changes of independent variables on the function.

In some instance, the concept of relative sensitivity representing the influence of relative changes of independent variables on relative variation of function is more convenient to express the influence of parameters. The definition of relative sensitivity of function f on parameter p_j [2] is expressed in the form

$$S[f|p_j] = \lim_{\Delta p_j \rightarrow 0} \frac{\Delta f/f}{\Delta p_j/p_j} = \frac{p_j}{f} \frac{\partial f}{\partial p_j}, \quad (21)$$

where $f = f(p_1, p_2, \dots, p_n)$ is investigated function, p_j is independent variable, resp. some parameter of structure.

The concept of relative sensitivity is used to analyse the effect of individual structural parameters on modification function f_m .

3. Numerical results

The modification function defined by equation (20) is suitable to evaluate the effect of material and geometrical parameters of individual parts on modification of mass and stiffness characteristics of composite beam structure and modification of natural frequencies. The fundamental parameters influencing the function f_m are material density, Young modulus and geometry of cross section. The non-dimensional parameters defined by equations (12)–(18) are used to generalise obtained results.

The analyses are performed for two cases of beam cross sections:

- type I: circular cross section of beam — circular cross section of core (Fig. 1a),
- type II: square cross section of beam ($b = h$) — circular cross section of core (Fig. 1b).

The dependency of modification function f_m on ratio of dominant dimensions of cross sections (beam type I; Fig. 1a)

$$\kappa_d = \frac{d_c}{d},$$

for different values of κ_E and fixed parameters κ_ρ are shown in Fig. 2 and for different values of κ_ρ and fixed parameters κ_E are shown in Fig. 3.

The effect of variation of dominant dimension ratio (beam type II; Fig. 1b)

$$\kappa_d = \frac{d_c}{h},$$

on modification function f_m for different values of κ_E and fixed parameters κ_ρ is presented in Fig. 4 and for different values of κ_ρ and fixed κ_E in Fig. 5.

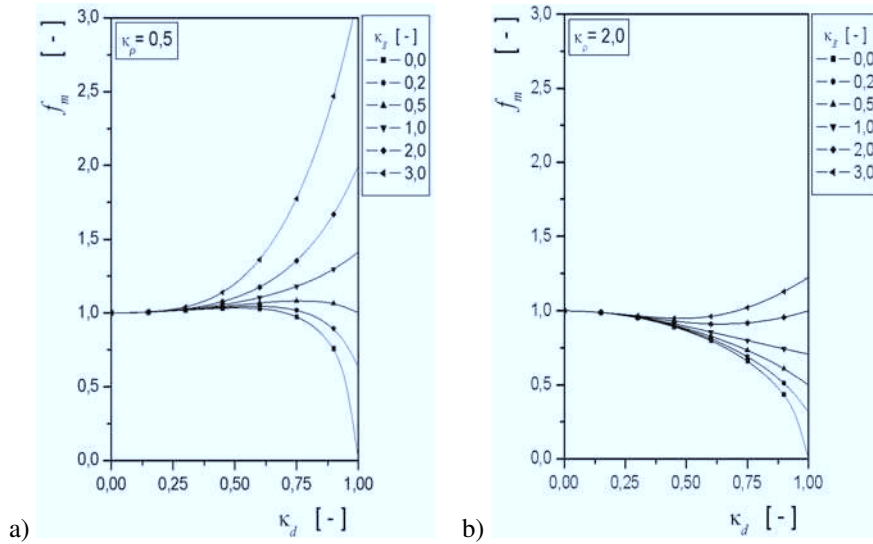

Fig. 2. The dependency of modification function f_m of beam type I on κ_d parameter for different parameters κ_E and fixed parameter, a) $\kappa_\rho = 0,5$; b) $\kappa_\rho = 2,0$

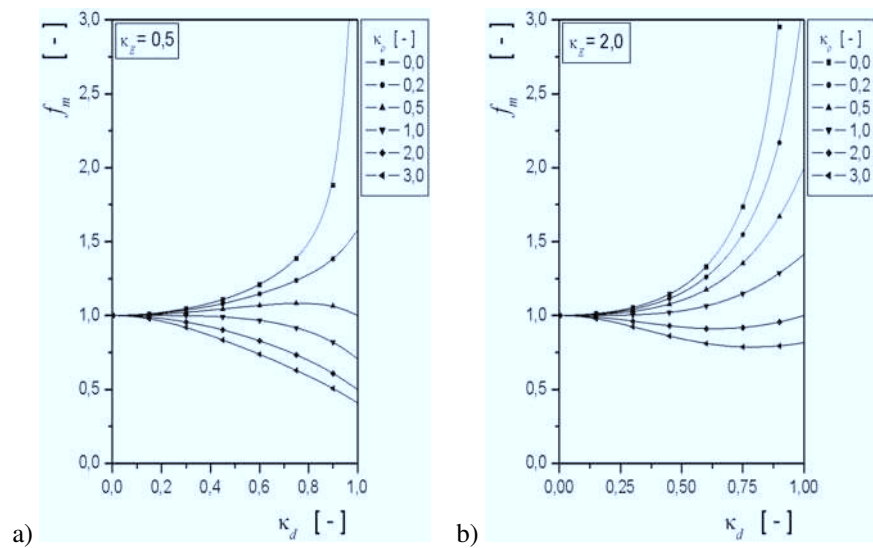

Fig. 3. The dependency of modification function f_m of beam type I on κ_d parameter for different parameters κ_ρ and fixed parameter, a) $\kappa_E = 0,5$; b) $\kappa_E = 2,0$

From graphs in Fig. 2 to Fig. 5 follows that modification function f_m is dependent on mutually combination of mutually independent parameters, i.e. parameters κ_E , κ_ρ , κ_d . To the better comprehension and explanation of modification of dynamic properties of analysed composite beam structure, the dependency of modification function f_m on parameter of mass modification $\Delta_{\rho S}$ is shown in Fig. 6. The dependency of modification function f_m on parameter of flexural rigidity modification Δ_{EJ} is presented in Fig. 7.

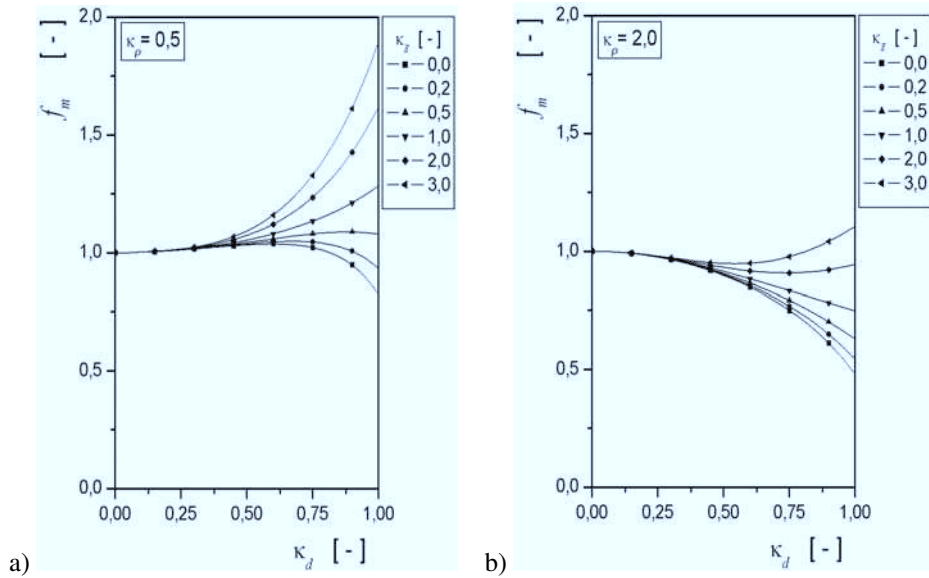

Fig. 4. The dependency of modification function f_m of beam type II on κ_h parameter for different parameters κ_E and fixed parameters $\kappa_d = 1,0$ and a) $\kappa_\rho = 0,5$; b) $\kappa_\rho = 2,0$

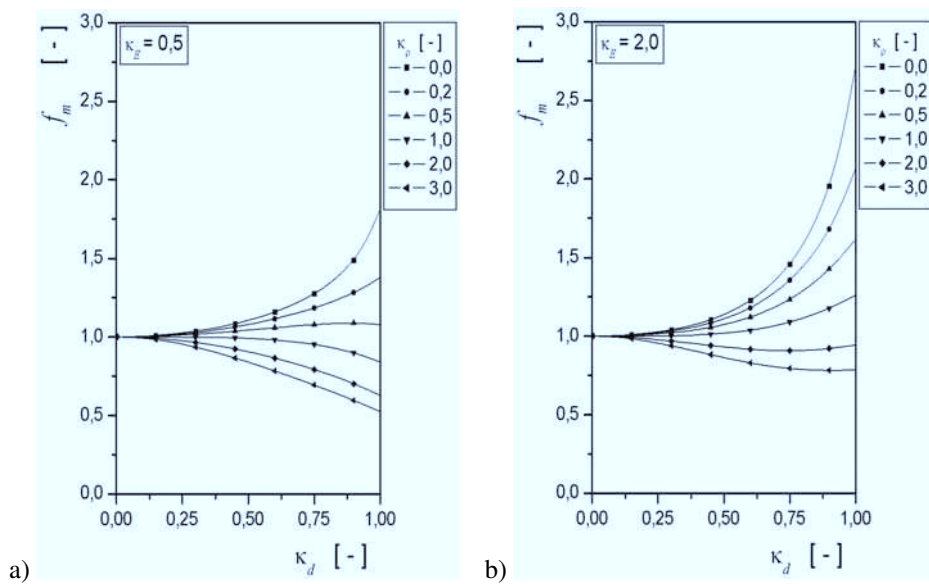

Fig. 5. The dependency of modification function f_m of beam type II on κ_d parameter for different parameters κ_ρ and fixed parameters $\kappa_d = 1,0$ and a) $\kappa_E = 0,5$; b) $\kappa_E = 2,0$

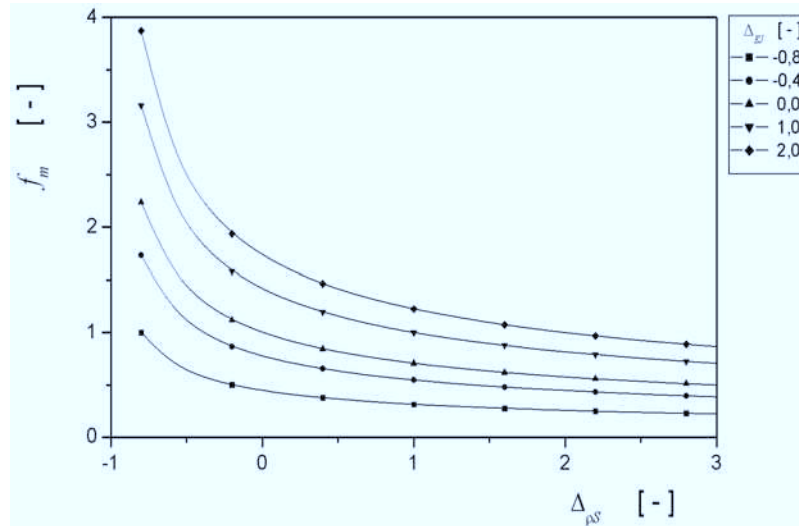

Fig. 6. The dependency of modification function f_m on parameter of mass modification of beam structure $\Delta_{\rho S}$ for different parameters of flexural rigidity modification Δ_{EJ}

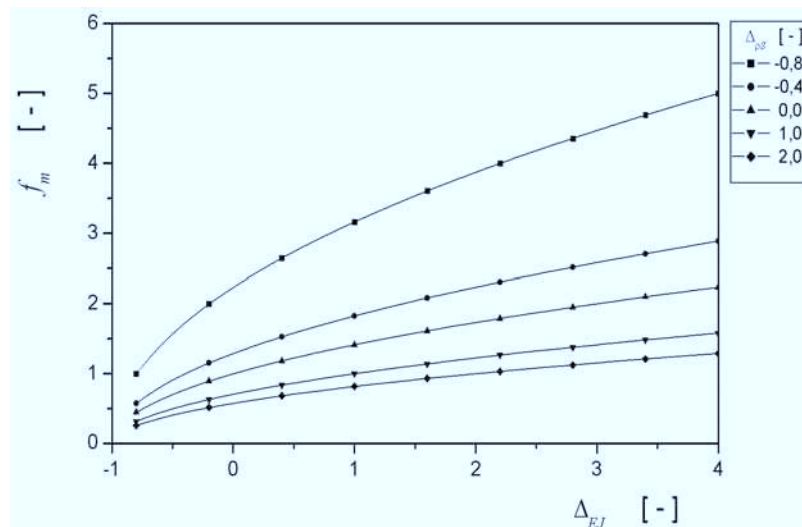

Fig. 7. The dependency of modification function f_m on parameter flexural rigidity modification of beam structure Δ_{EJ} for different parameter of mass modification $\Delta_{\rho S}$

The dependencies in Fig. 6 and Fig. 7 are valid for both considered cases of composite beam structures, resp. for arbitrary beam cross section with cross section of core symmetric to neutral axis of composite beam structure.

The dependency of relative sensitivity of modification function on parameter of mass modification $\Delta_{\rho S}$ is shown in Fig. 8 and dependency of relative sensitivity $S[f_m | \Delta_{EJ}]$ of function f_m on parameter of flexural rigidity modification Δ_{EJ} is shown in Fig. 9.

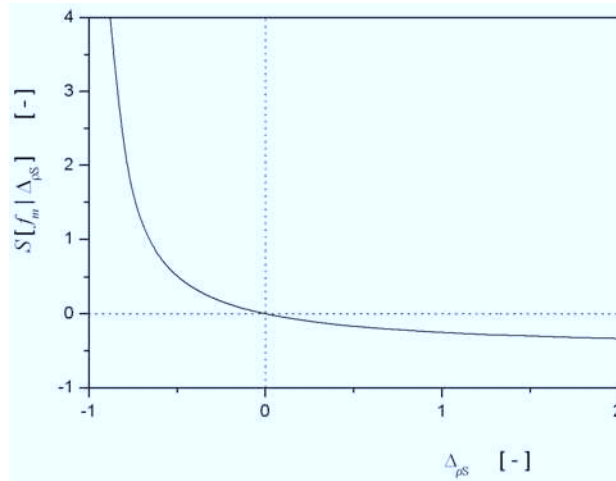

Fig. 8. The dependency of relative sensitivity of modification function f_m on mass modification parameter $\Delta_{\rho S}$

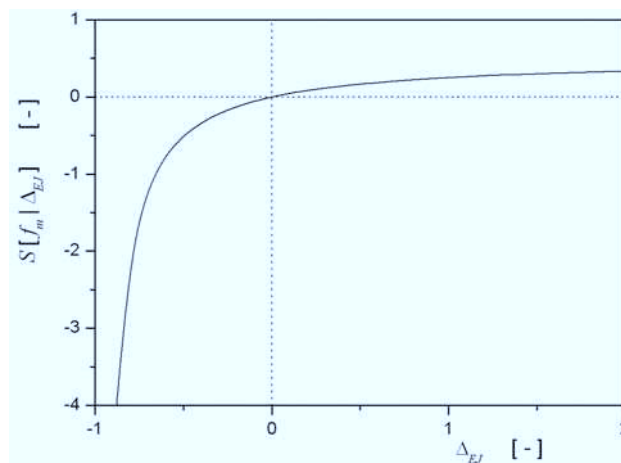

Fig. 9. The dependency of relative sensitivity of modification function f_m on parameter of flexural rigidity modification Δ_{EJ}

4. Conclusion

The bodies of machining tools can be in many cases considered as a clamped beam structures. The main aim of this paper was to analyse the dynamical properties (natural frequencies) of the cantilever beam composite structure representing the vibrating body of machining tool.

The modification of dynamical properties of cantilever beam structure by reinforcing the core is presented in this paper. The modification of natural frequencies of clamped composite beam structure is carried out by variations of material properties and geometrical dimensions of beam core. The modification function (20) to determinate the natural frequencies of modified beam structure depends on non-dimensional material and geometric core parameters. The inter-

esting and important result is that the natural frequencies of modified composite beam structure can be determined by multiplying the natural frequencies of unmodified structure by modification function. Moreover, the modification function of modified structure has the same value for all natural frequencies of the modified structure. Then the required natural frequencies of composite beam structure can be obtained by convenient combination of the non-dimensional parameters $\Delta_{\rho S}$ and Δ_{EJ} . The effect of non-dimensional material and geometric parameters of composite beam structure on modification function is analysed and presented (see Fig. 2–5). The dependence of the relative sensitivity analysis of modification function on structural mass modification and structural flexural rigidity modification was investigated.

After intensive search for the current state of the art in the field of tool body design was not found the comparable structures. With respect to the facts mentioned in the first part of this paper, presented manner of arrangement of the composite beam structure fulfils specific requirements which have to satisfy the machining tool bodies.

The results obtained confirm that this manner of the structural modification of the beam offers very effective tool to modification of dynamical properties or dynamical tuning for similar beam structures.

Acknowledgements

The work has been supported by the grant projects VEGA-1/0256/09 and VEGA-1/0090/08.

References

- [1] ASM Handbook — Machining, Vol. 16, 1995.
- [2] S. Gu, The development and state in art of structure dynamic modification, *Mechanical Strength* 13(1) (2002) 1–9.
- [3] J. He, Structural modification, *Phil. Trans. of Royal Society, London*, (2001) 359, 187–204.
- [4] I. d. Marinescu, I. Constantin, D. Boboc, *Handbook of machine tool analysis*, Marcel Dekker, Inc., New York, 2002.
- [5] L. Meirovitch, *Analytical methods in vibrations*, The MacMilan Company, London, 1967.
- [6] T. Nánási, Exotic natural frequencies of coupled beams, *Proc. of the 11th International Conference — Noise and Vibration in Practice*, Kočovce, STU Bratislava, 2006, pp. 71–74.
- [7] T. Nánási, Stability if vibrating beam in torsion and compression, *Proc. of the 12th International Conference — Noise and Vibration in Practice*, Kočovce, STU Bratislava, 2007, pp. 61–64.
- [8] A. G. Rehorn, Jin Jiang, P. E. Orban, State-of-the-art methods and results in tool condition monitoring: a review, *Int J Adv Manuf Technol* (2005) 26, pp. 693–710.
- [9] S. P. Timoshenko, D. H. Yang, U. Uiver, *Oscillations in the Engineering*, Moscow, Mashinostroyeniye, 1985. (in Russian)
- [10] H. A. Youssef, H. El-Hofy, *Machining technology: Machine tools and operations*, CRC Press, 2008.