

Dynamic Model of Stirling Engine Crank Mechanism with Connected Electric Generator

M. Sikora^{a,*}, R. Vlach^a

^a*Institute of Solid Mechanics, Mechatronics and Biomechanics, Faculty of Mechanical Engineering, Brno University of Technology,
Technická 2896/2, 616 69 Brno, Czech Republic*

Received 30 August 2008; received in revised form 4 December 2008

Abstract

This paper treats of a numerical dynamic model of Stirling engine crank mechanism. The model is included in the complex model of combined heat and power unit. The unit is composed of the Stirling engine and of attached three-phase synchronous generator. This generator should start the Stirling engine in motor mode as well. It is necessary to combine the crank shaft dynamic model and the complete thermal model of Stirling engine for simulations and analyses of engine run. Our aim is to create a dynamics model which takes into account the parameters of crankshaft, piston rods, pistons, and attached generator. For unit working, the electro-mechanical behaviour of generator is also important. That is why we experimentally verified the parameters of generator. The measured characteristics are used in a complex model of heat and power unit. Moreover, it is also possible to determine the Stirling engine torque by the help of these electro-mechanical characteristics. These values can be used e. g. for determination of optimal engine working point or for unit control.

© 2009 University of West Bohemia. All rights reserved.

Keywords: combined heat and power unit, Stirling engine, crank mechanism, synchronous generator, model, simulation

1. Introduction

In context of some global problems, we can characterize the beginning of the 21st century as a period of energy losses minimisation. One of the ways, how to efficiently use energy sources, is the use of combined heat and power unit. A decentralized generation of electrical energy and heat is not efficient. The most of heat, which engenders in the course of electric energy generation in power plants, is usually released into ambient atmosphere. In contrast to this, the waste heat from the combined in — house heat and power unit can be used for house heating.

Combined heat and power units can be powered by the help of various types of combustion engines, e. g. diesel engines, gas engines or engines with external heat inlet. The advantage of engines with external heat inlet (e.g. Stirling engine) is a modesty of fuel quality because the fuel can be burned continually. It is possible to use low-quality, renewable sources of power, e.g. biomass gas.

Fig. 1 illustrates a conception of small combined heat and power unit connected to the electric network. Our aim is to create a complex numerical model of a similar unit. This model should serve for the preliminary analysis of unit behaviour and for the acquisition of data which we can be used for control unit design. One of our sub-goals is to create a dynamic crankshaft model and a generator model.

*Corresponding author. Tel.: +420 737 573 200, e-mail: ysikor01@stud.fme.vutbr.cz.

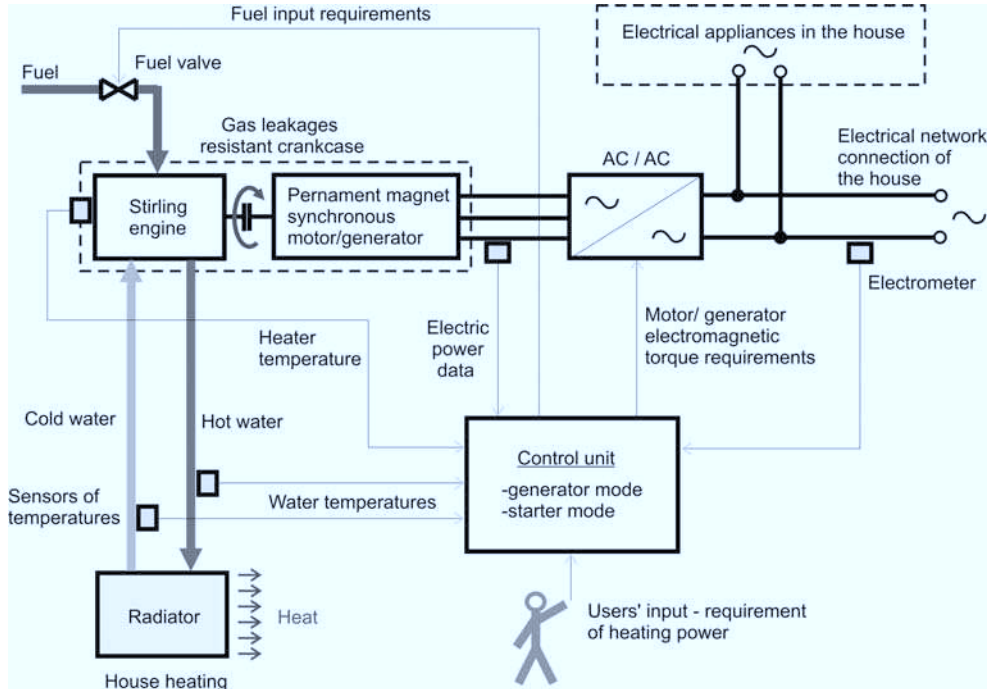

Fig. 1. The scheme of combined heat and power unit with Stirling engine for a common house

2. Conception of numerical model for small combined heat and power unit

We have already developed a thermal (numerical) model of the Stirling engine. This model is implemented in Matlab and is based on the final volume method (FVM). So far only a constant angular velocity of the shaft has been considered in the thermal model which could not be used for engine starting simulations. Therefore, a dynamic model of engine crank mechanism will have to be added. Consequently, there is a requirement for compatibility of these models. The mechanical and thermal models will be connected to create a complex model of Stirling engine. Then, an electro-mechanical sub-model of generator can be also added. Our final objective is a complex model of combined heat and power unit.

The idea of final heat and power unit model and relations among particular sub-models are presented in Fig. 2.

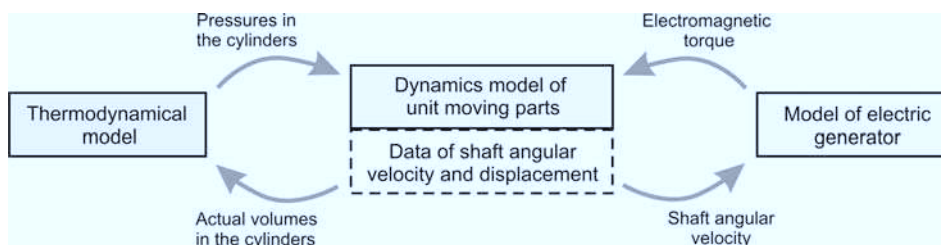

Fig. 2. Diagram of complex heat and power unit model implemented in Matlab

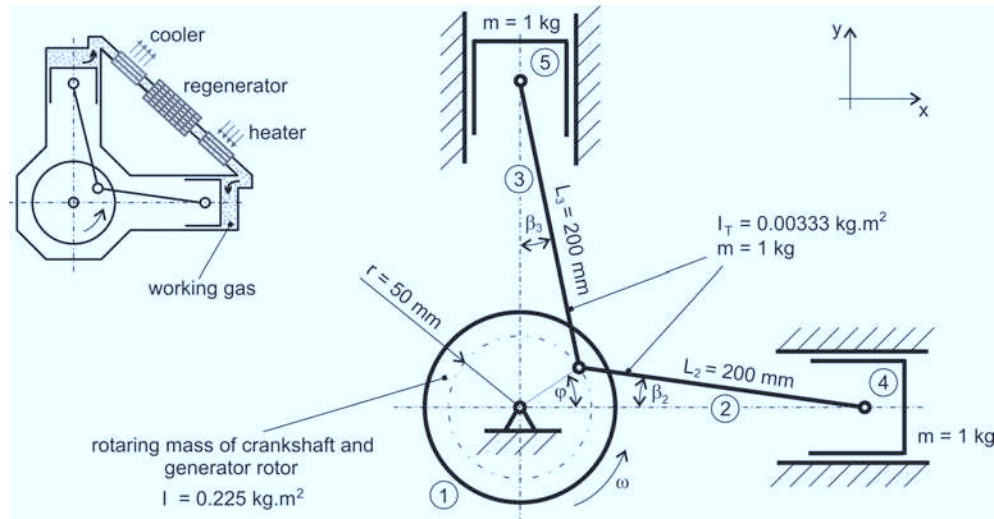

Fig. 3. Scheme of Stirling engine crank mechanism with added rotating mass of generator rotor

3. Geometry and arrangement of Stirling engine crank mechanism

The main parts of Stirling engine crank mechanism are a crankshaft with balance wheel, two pistons and two piston rods. These bodies are the most important parts for calculations of engine dynamics.

Dynamic behaviour of this mechanism is also affected by the electric generator which is connected to the Stirling engine crankshaft. Therefore, we can assume the rotor of generator as a fixed component of the crankshaft. As a consequence of this, it is necessary to take into account the sum of crankshaft angular momentum and angular momentum of generator rotor.

For proper operation of alpha — type Stirling engine it is important to consider a phase difference between motions of pistons. The most common phase difference is 90° for a lot of Stirling engines as stated in [1] or [3]. The scheme of this Stirling engine (alpha configuration) is in Fig. 3. Our institute is not the owner of illustrated alpha — type Stirling engine, but we intend to consider the geometry and selective values shown in the above figure for further calculations. The position of crank on the axis of horizontal cylinder is considered as the zero value of crank tilting angle.

4. Solution to crank mechanism dynamics

4.1. Used method

The crank mechanism is composed of five bodies. For further calculations, these bodies are considered as bodies with lumped parameters in the centres of gravity.

We used the method of virtual work principle to solve dynamic behaviour of crank mechanism. There are also some other methods but the method of virtual work principle is relatively advantageous because it is not necessary to know an action of force among mechanism parts. We are especially interested in the shaft motion; shaft angular acceleration can be estimated by the method of virtual work principle.

The essence of this method can be expressed as follows:

$$\sum_{i=1}^n (\vec{Q}_i + \vec{Q}_{si}) \delta \vec{q}_i = 0. \quad (1)$$

Where \vec{Q}_i is a generalized influence of external forces, \vec{Q}_{si} is a generalized inertia influence of body and $\delta \vec{q}_i$ is a virtual displacement. Equation (1) can be adapted for five bodies considered in crank mechanism:

$$(M_1 - M_{s1})\delta\varphi_1 + (0 - M_{s2})\delta\varphi_2 + (0 - F_{sx2})\delta x_2 + (0 - F_{sy2})\delta y_2 + (0 - M_{s3})\delta\varphi_3 + (0 - F_{sx3})\delta x_3 + (0 - F_{sy3})\delta y_3 + (F_4 - F_{s4})\delta x_4 + (F_5 - F_{s5})\delta y_5 = 0. \quad (2)$$

In this equation, M_1 is a sum of torques on crankshaft, for example generator torque. F_4 and F_5 are sums of forces acting on pistons, such as gas pressure forces and friction forces.

We consider the virtual angular displacement $\delta\varphi_1$ as independent virtual displacement. Then, we have to express other virtual displacements $\delta\varphi_i$, δx_i and δy_i (i is index of body, see Fig. 3) by the help of $\delta\varphi_1$. For example, virtual angular displacement $\delta\varphi_2$ can be expressed as follows:

$$\delta\varphi_2 = -\frac{\delta\varphi_1 \cdot r \cdot \cos(\varphi)}{L_2 \cdot \cos(\beta_2)}. \quad (3)$$

We can express the inertia influences of bodies by the help of body mass (or angular momentum) and by (angular) acceleration, for example:

$$M_{s2} = I_2 \cdot \alpha_2. \quad (4)$$

Then, accelerations have to be expressed by the independent angular acceleration of crankshaft α_1 . For example, angular acceleration of piston rod can be expressed as follows:

$$\alpha_2 = -\frac{\alpha_1 \cdot r \cdot \cos(\varphi)}{L_2 \cdot \cos(\beta_2)}. \quad (5)$$

If we substitute inertia influences of bodies and virtual displacements in equation (2), we will be able to express angular acceleration of crankshaft α_1 as function of these parameters:

$$\alpha_1 = f(m_i, I_i, r, L_2, L_3, \varphi, F_{gas}, F_{friction}, M_{generator}). \quad (6)$$

Finally, the crankshaft angular velocity and shaft angular displacement can be calculated by numerical integration of shaft angular acceleration.

4.2. Modelling of friction in crank mechanism

The most important surface friction forces in the Stirling motor are acting at the piston-cylinder contacts. The influence of the bearing friction is insignificant for our simulations. We consider only constant friction coefficients for the present. We can divide the piston-cylinder friction force in two components:

The first component of friction force relates to the normal forces between piston rings and surface of cylinder (due to pre-stress of piston rings). These components are considered to be constant.

The second component of friction force relates to an external action of forces at the piston, i.e. that this second component of friction force is dependent on the piston rod force. It is

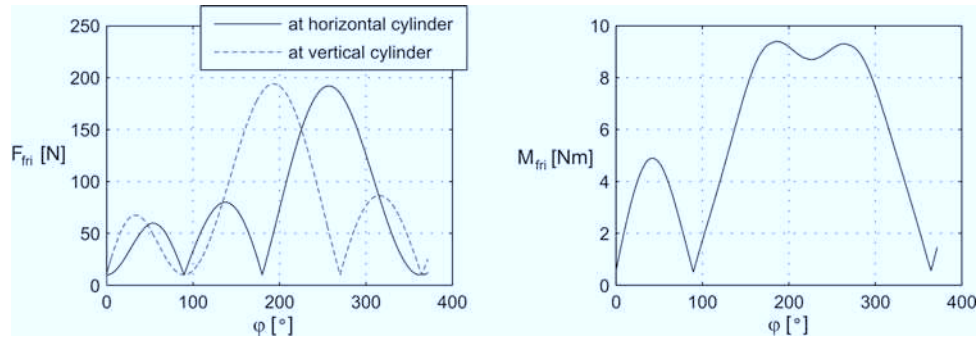

Fig. 4. Magnitudes of friction forces (left) and behaviour of “friction torque” (right), all in relation to crank tilting angle

possible to calculate the piston rod force by the help of gas pressure, actual rod geometry, and piston acceleration.

Friction forces always act against piston motions. For our better understanding of friction effect, we can convert these components of friction force to “friction torque” which is related to the crankshaft. Friction forces and computed “friction torque” during one working cycle of Stirling engine are presented in Fig. 4. It is evident that these friction forces will be minimal when the pressure of working gas and pressure of gas in crank case achieve the same values (piston rods forces are very small at the moment).

5. Generator for combined heat and power unit

5.1. Generator description

There is one of the electric generators, which can be connected to the Stirling engine. It is a three-phase synchronous machine with a drum shaped permanent magnets rotor (see Fig. 5.) Stator windings are joined in neutral point (star-configuration), neutral is not brought-out. The grooves, which separate the stator stampings, are slightly skew in order to smooth behaviour of output voltage. The number of pole couples is 18 so that it is relatively low-speed machine.

The generator is usually situated inside of hermetical crankcase of Stirling engine. In this case, engine power is transmitted out only by electric wires.

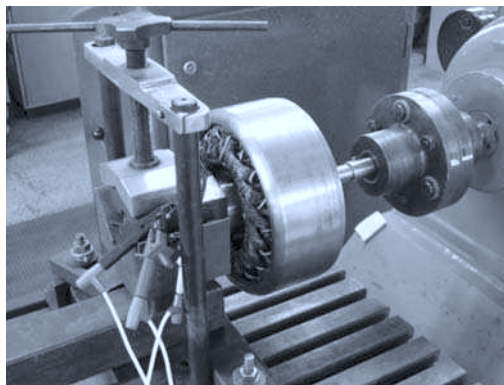

Fig. 5. The measured generator at testing position

5.2. Steady state theory of generator

The equations, which describe the behaviour of synchronous generator with permanent magnets, are similar to equations for DC machine as was stated in [2].

The equation for the phase generated RMS voltage:

$$U_{p0} = c \cdot \phi \cdot \omega. \quad (7)$$

Where $c \cdot \phi$ is constant of this machine, which depends on the machine construction. The machine shaft torque relates with phase current I :

$$M = 3 \cdot c \cdot \phi \cdot I. \quad (8)$$

The equation for the output phase to neutral RMS voltage:

For generator mode:

$$U = c \cdot \phi \cdot \omega - R_a \cdot I. \quad (9)$$

For motor mode:

$$U = c \cdot \phi \cdot \omega + R_a \cdot I. \quad (10)$$

Where R_a is resistance of stator winding. The relation between rotor angular velocity ω and frequency of voltage f can be expressed as:

$$\omega = \frac{2 \cdot \pi \cdot f}{p}. \quad (11)$$

Where p is number of stator pole couples.

The implemented sub-model of electric generator in complex unit model is based mainly on these relations. For identification of some generator characteristics and parameters, such as $c\phi$ constant or resistance of winding R_a , we have to carry out generator measuring.

5.3. Generator measuring

With regard to the design of generator and laboratory facilities, we carried out the following measuring: measuring of winding resistance, measuring of off-load voltage, measuring of iron losses and mechanical losses and measuring of ohmic load machine.

This synchronous machine should also work in motor mode as the Stirling engine starting gear. We did not measure the machine in motor mode because it needs a relatively complicated control of power supply unit. But the characteristics in motor mode and generator mode are similar for many of synchronous machines as was stated in [2].

The most important measured characteristics are off-load voltage on the engine speed relation and torque-current relation, see Fig. 6.

It is possible to estimate the $c\phi$ constant by the help of these characteristics and equation (7) or (8), $c\phi = 1.67$. The calculated generator efficiency is just about 83 % and power factor $\cos(\varphi) = 1$. The torque-current characteristic is almost linear (it corresponds with equation (8)), but not ideally linear. Therefore we do not use the linear torque equation (8) in the model, but we approximate the measured data by the help of regression analysis. The resulting regression function for shaft torque is as follows:

$$M = 0.8181 + 5.0434 \cdot I - 0.0432 \cdot I^2. \quad (12)$$

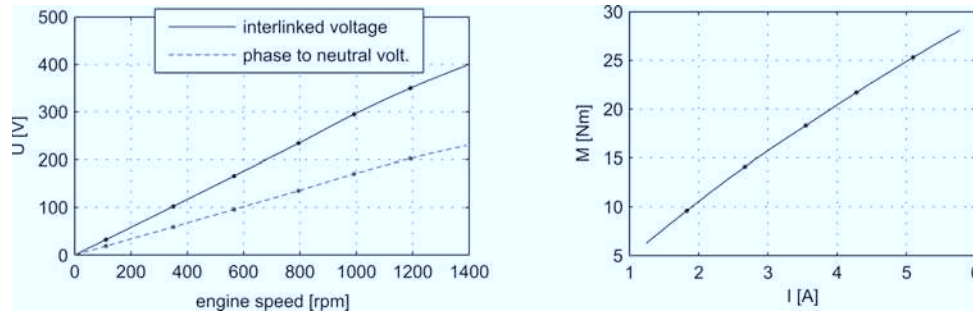

Fig. 6. Relation of off-load RMS voltage on the engine speed (left) and relation of shaft torque versus phase current (right)

We can see that the first equation term is independent of the phase current. It is due to generator off-load residual torque (iron losses and mechanical losses). The last negative equation coefficient corresponds with the magnetic oversaturation of machine.

We can also accurately assess the Stirling engine speed and shaft torque by the help of measured electrical values on the generator output. It is easy to measure the phase current and use its values in the torque regression function (12). Voltage frequency enables us to determine the engine speed. Knowledge of Stirling engine mechanical values is advantageous e.g. for determination of engine optimal working point.

6. Differential equation system of completed complex model

We have implemented three sub-models (see Fig. 2) in the complex model. The most complicated is the thermal sub-model of Stirling engine. We can divide the solution of thermal phenomena into two logical parts. The whole complex model is represented by the system of several non-linear differential equations and by other auxiliary relations. The sequence of solved equations can be briefly described as follows:

1. First part of solution of thermal phenomena: We consider closed imaginary walls among gas elements.
 - determination of actual gas volumes (in cylinders and crankcase)
 - evaluation of gas properties (viscosity, thermal capacity, etc.)
 - estimation of heat transfer coefficients
 - calculation of volume work increases (in elements of cylinders and crankcase)
 - calculation of heat increases (convection heat transfers)
 - preliminary evaluation of gas temperatures and pressures
2. Second part of solution of thermal phenomena: Imaginary walls among gas elements are open and the pistons do not move.
 - estimation of gas flows among elements (increases of gas mass into elements)
 - estimation of pressure losses among gas elements (as a result of estimated gas flows)
 - estimation of new values of gas variables (gas masses in elements, temperatures, pressures)
 - Comparing of actual elements pressures differences and pressure losses. If these differences are not sufficiently small, estimating of gas flows will be repeated.

3. calculation of current across the generator output, calculation of generator torque
4. evaluation of piston rod forces, friction forces and gas pressure forces across pistons
5. calculation of shaft angular acceleration (by equation (6))

This system of equations is implemented in Matlab and is numerically solved.

7. Examples of simulations results

The following results were obtained by the help of the complex model of combined heat and power unit. We can run simulations with various pre-sets and analyse the behaviour of many variables. The thermal model of Stirling engine works in the following simulations with parameters which are common for alpha-configuration Stirling engines and are stated in [1]. Fig. 7 illustrates behaviour of some important variables during one Stirling engine cycle. We can see that the engine torque oscillates between positive and negative values. However the mean value of the torque is positive during one cycle and the engine is able to perform the work.

One of the important engine characteristics is a necessary torque for Stirling engine start-up. The following torque values (see Fig. 8) were determined for different initial crank tilting angles and for initial gas pressure of 1 MPa. The necessary starting torque is very dependent on the working gas pressure in the Stirling engine. We can see that the extremes of necessary starting torque relate to the extremes of working gas volumes, compare Fig. 7 and Fig. 8.

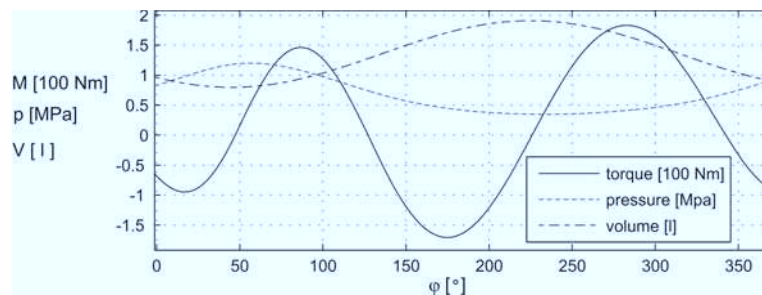

Fig. 7. Behaviour of engine torque, mean gas pressure and working gas volume in relation to crank tilting angle during one working cycle

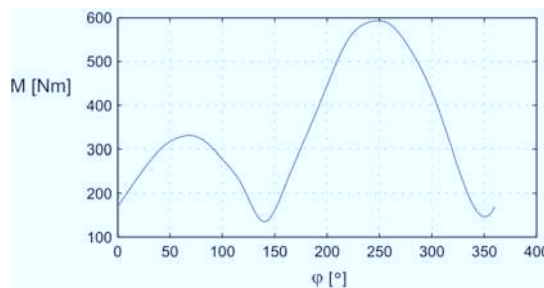

Fig. 8. The relation of minimal starting torque versus initial crank tilting angle

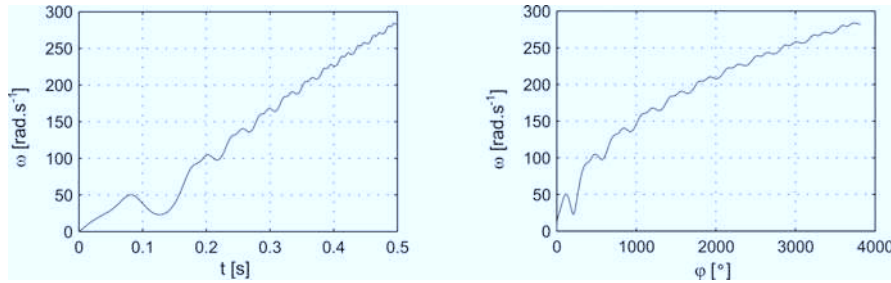

Fig. 9. The starting of Stirling engine by force of constant external torque. The relation of shaft angular velocity versus the time (left) and versus the crank tilting angle (right)

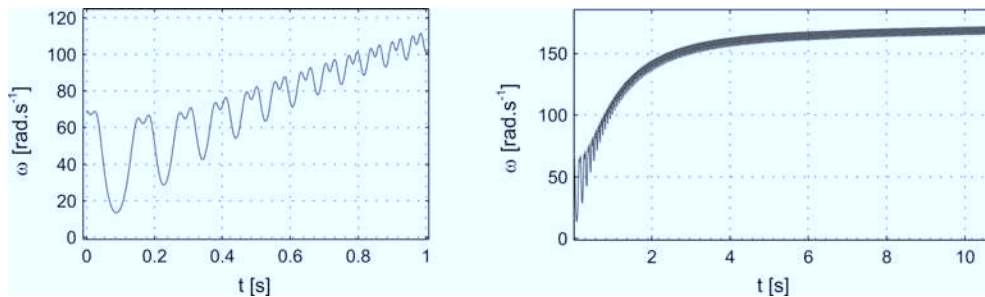

Fig. 10. The relation of the shaft angular velocity versus the time. The initial machine speed is approximately 660 rpm in time $t = 0$ s. This initial shaft angular velocity is sufficient for next self-acceleration of engine

The example of the engine start-up can be seen in Fig. 9. The cause for irregularity of shaft angle velocity is especially the varying pressure of working gas and changes of actual parts in relation to the position during the engine working cycle.

Fig. 10 illustrates the behaviour of shaft angular velocity after engine rev up. There is not any ohmic load across the generator output in this simulation. After some time, the shaft angular velocity will achieve a constant free-running value.

The next picture (Fig. 11) represents the example of shaft angular velocity behaviour during the following working sequence:

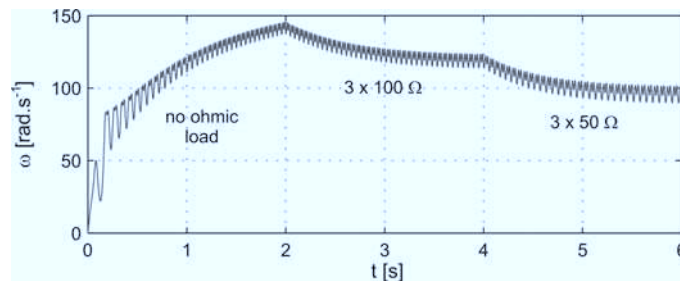

Fig. 11. The example of angular velocity behaviour during working sequence with changes of ohmic load

1. starting the engine by the help of external torque (until $\omega > 75 \text{ rad} \cdot \text{s}^{-1}$)
2. self-acceleration of engine, no ohmic load across the generator output
3. run with the ohmic load of $3 \times 100 \Omega$ (star configuration) across the generator output ($2 \text{ s} < t < 4 \text{ s}$)
4. run with the ohmic load of $3 \times 50 \Omega$ (star configuration) across the generator output ($t > 4 \text{ s}$)

In Fig. 11, we can see the changes of angular velocity in relation to the changes of ohmic load.

8. Conclusion

The presented numeric model of Stirling engine shaft includes all important phenomena of crank mechanism. This sub-model is included in the complex model of combined heat and power unit, which also contains the generator sub-model.

The simulations disclose some problems in the intended conception of unit. Firstly, torque is crucial for Stirling engine starting. The used generator is not able to achieve the necessary value of torque in motor mode. Therefore, the engine power and power of generator should be better equilibrated. Start-up and operation at lower working gas pressure can also solve this problem if other parameters of engine or generator are not changed. It was also confirmed that the change of shaft angular momentum did not have any influence on the necessary starting torque.

The unit with these parameters is also not able to run if the machine speed is lower than 600 rpm. The increase in shaft angular momentum would extend the machine speed range.

The created complex model can be used for further design of electric converter and for system of unit control. However it is necessary to investigate some unit parameters more precisely.

Acknowledgements

Published results were acquired using the subsidy from the Ministry of Education, Youth and Sports of the Czech Republic, research plan MSM 0021630518 “Simulation modelling of mechatronic systems”.

References

- [1] W. Martini, Stirling Engine Desing Manual, second edition, Martini Engineering, Richland, Washington 99352, 1983.
- [2] P. Vorel, Permanent magnets synchronous machines, CERM, Brno, 2005 (in Czech).
- [3] G. Walker, Stirling-cycle machines, Clarendon press, Oxford, 1973.