

PHOTOVOLTAIC SYSTEM OVERVOLTAGE PROTECTION

Jaroslav Petráš, Jozef Balogh

ABSTRACT

This paper deals with overvoltage protection strategy and methods for photovoltaic systems as renewable energy source. It describes some sample circuit connection with overvoltage protection devices and some overvoltage protection device types.

1. INTRODUCTION

World consumption of energy gets higher and higher every year. With this energy demand increase most of the energy sources used so far appears to be insufficient and exploitable in relatively short time horizons. One of the alternative solutions is to increase the contribution of renewable energy sources. Among these sources like e.g. wind power plants has an important place also the exploitation of solar energy. Solar light energy exploitation uses photovoltaic effect. It is expected that in some years a contribution of solar power plants as the cleanest energy source will be much higher than in these days. This requires an installation of more and more photovoltaic and solar systems.

2. SITUATION AND CONSTRUCTION OF PHOTOVOLTAIC SYSTEMS

A photovoltaic system element is the basic part for solar radiation change into electrical energy. May this element be made of any material it is always a large surface semiconductor device with one or more PN junctions. The dimensions of commercially made elements are not larger than 200mm and their thickness does not exceed 400 μ m. So they represent very thin semiconductor device.

In addition solar panels require installation places with direct overvoltage hazard due to atmospheric discharges. These places include building rooftops and external places on the terrain level. In both cases lightning conductor system installation is possible (or may be used a system that already exists).

In the case without lightning conductor system the solar panels are situated according to direct and indirect lightning effect in the LPZ 0_A lightning protection zone, if there is a lightning conductor system, panels are situated in LPZ 0_B zone, (defined according to IEC 1312-1 and STN EN 62305).

In the zone LPZ 0_A with undamped electro-magnetic field a system of photovoltaic panels is exposed to hazard of direct lightning hit (full lightning current transfer). In the zone LPZ 0_B there is no hazard of direct lightning hit but there is still the hazard of undamped electro-magnetic field.

3. OVERVOLTAGE PROTECTION OF PHOTOVOLTAIC SYSTEMS

The facts mentioned above result in the demand for overvoltage protection for photovoltaic panels. With the increase of this kind of energy source the reliability of source operation gets more important. This includes also protection strategy against energy supply drop-outs caused by lightning hit into unprotected solar power plants.

As of now there are many producers that have added very flexible to their product ranges also overvoltage protection devices designed especially for photovoltaic panels. These products are mainly classified into I + II class of overvoltage protection device types.

These are e.g. compact I + II (according to IEC 61643-1 and STN EN 61643-11) protection devices (Fig. 1). They are made especially for the protection of positive and negative buses of photovoltaic panels against overvoltage. It is advisable to connect these devices on the interface of LPZ 0_{A(B)} zones – 1 and above.

From the construction point of view they consist of varistors or varistor sections connected between L+, L- and PE wires. Varistor sections have internal disconnecters that are activated during faults or in the case of varistor overheating. Disconnecters indicate their state usually mechanically. Additionally, overvoltage protection devices can be equipped with remote signaling of faulty devices.

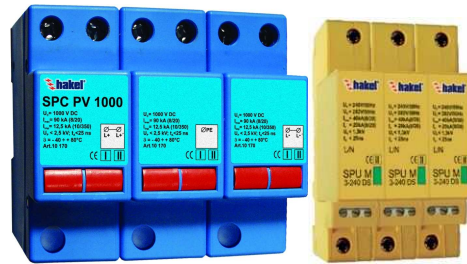

Figure 1 – Overvoltage protection devices (HAKEL producer)

Protection devices usually have various levels of maximal continuous DC voltage U_C (e.g. 200, 400, 600, 800 a 1000V) and various values of voltage protection level (at I_{imp}) U_P (e.g. smaller than 250, 1100, 2000, 2400 and 3400V). Maximal leakage current is also an important parameter - I_{max} (8/20 shaped wave) can be e.g. 120kA.

On Fig. 2 and 3 there are depicted some sample connections of these device types:

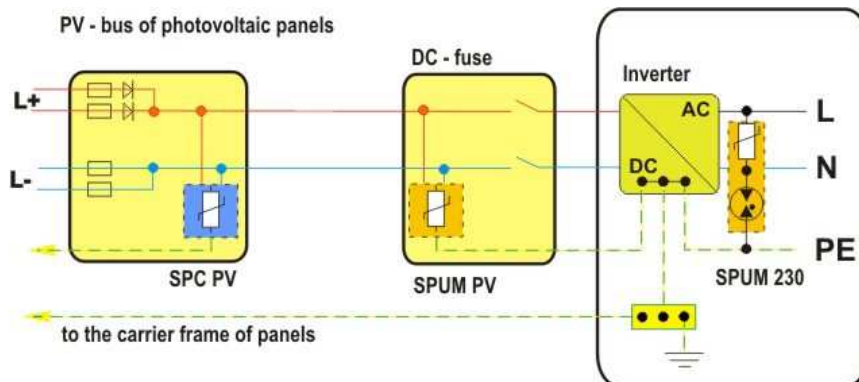

Figure 2 – Overvoltage protection device connection examples (e.g. HAKEL SPUM PV)

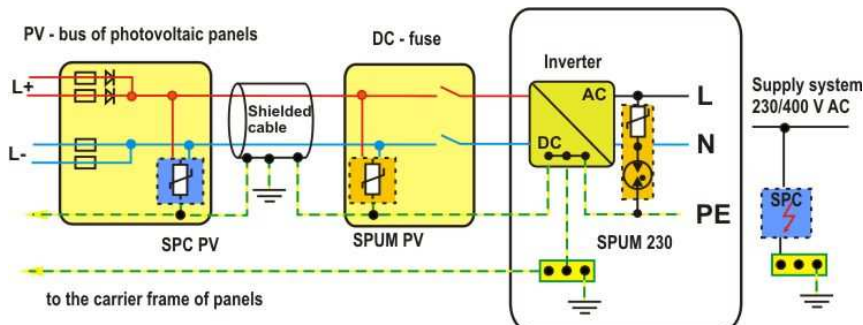

Figure 3 – Overvoltage protection device connection examples (e.g. HAKEL)

4. CONCLUSIONS

With the increase of renewable energy sources and especially solar power plants the reliability of source operation gets more important. The question of protection strategy against energy supply drop-outs caused by lightning hit into unprotected solar power plants is very important nowadays and requires also the knowledge in the area of overvoltage protection system design.

REFERENCES

- [1] Katalóg produktov HAKEL 2007 – Zvodiče prepätia
- [2] *Petráš, Jaroslav et al.*: Ochrana fotovoltaických a solárnych systémov. In: Strojárstvo. roč. 11, č. 7-8 (2007), pp. 68-69. Internet: www.strojarkstvo.sk ISSN 1335-2938.

ACKNOWLEDGEMENT

Táto publikácia vznikla vďaka podpore v rámci operačného programu Výskum a vývoj pre projekt: Centrum výskumu účinnosti integrácie kombinovaných systémov obnoviteľných zdrojov energií, s kódom ITMS: 26220220064, spolufinancovaný zo zdrojov Európskeho fondu regionálneho rozvoja.



Authors:

Ing. Jaroslav Petráš, PhD.
Technical university of Košice
Faculty of electrical engineering and informatics
Department of Electrical Power Engineering
Mäsiarska 74, 040 01 Košice, Slovak Republic
E-mail: jaroslav.petras@tuke.sk
Tel: + 421 055 602 3564

Ing. Jozef Balogh, PhD.
Technical university of Košice
Faculty of electrical engineering and informatics
Department of Electrical Power Engineering
Mäsiarska 74, 040 01 Košice, Slovak Republic
E-mail: jozef.balogh@tuke.sk
Tel: + 421 055 602 3564