



September 10 - 12, 2007

Pilsen, Czech Republic

APPLICATION OF COM+ TECHNOLOGY FOR THE GRAPH ANALYSIS IN THE POWER SYSTEM

PROF. BERNARD BARON, PHD. ENG.
DR ARTUR PASIERBEK, PHD. ENG.
MR TOMASZ KRASZEWSKI, MSc. ENG.
MR ŁUKASZ OSUSZEK, MSc. ENG.

Abstract: Modelling the phenomena proceeds in the power system which consists of thousands of elements require much time and processor capacity. The paper describes proposal of using the COM+ technology to shorten computation time and acquire appropriate computing power. The experiment results relying on the time measurement of the power system graph analyses algorithm, obtained on one computer and a few computers working parallel have been shown.

Key words: parallel computer, calculation, numerical methods, power system

INTRODUCTION

Advancement of computer science produces continuous demand growth for computation power increasing. New formation of application requires more and more system resources. During the last 30 years the speed of computation has been increased about fifth order of magnitude. At the present the speed of calculation achieves about hundred of teraFLOP. However for a technological reason subsequent speed increasing is not so fast. Parallel computers can solve that problem.

Power optimisation of power system is very important to control power flow. This paper deals with graph analysis as a part of power optimisation in the power system.

1 POWER SYSTEM

The power system is a complicated system which consists of thousands of elements which are connected with each other. Such a system can be examined in a stationary or a non stationary state. However, regardless the examined state the information about all of elements are very needed, especially dependences among them.

Taking into account numbers of parameters consisting of information about: generating node (300), load node (2100), transmission line (2900), it is necessary to assume that total calculation time even on modern single PC could be very long.

A preliminary research shows that the time wanted to carry out full analysis of the graph of power system has been taking approximately 30 seconds. It is needed to mention that the analysis process is the lowest time-consuming part of total calculation time. Achieved results have been inclined authors to quest the calculation speedup.

2 INTELLIGENT CLUSTER OF ACTIVE COMPONENTS

In that work COM+ technology to increase speed of algorithms computing has been used. There is a couple of manners helping to gain this goal. The most likely way is parallel and concurrent computing. Basically parallel computing is simultaneous execution of the same task (split up and specially adapted) on multiple processors (computers) in order to obtain results faster. The idea is based on the fact that the process of solving a problem can be usually divided into smaller tasks, which may be carried out simultaneously with some coordination. Software designed by our team helps to analyse graph of power system much faster than traditional software.

Microsoft COM+ is very powerful technology which helps to design and create multithreaded parallel computed algorithms. It gives user very stable runtimes environment and many of useful system features like transactions, integration with Microsoft Active Directory, system and

web services and Loosely Coupled Events (features presented here are only little subset of all of functionalities of COM+ system). Our solution used this technology to gain parallel and concurrent computing.

Theoretical model of discussed system assumes collaboration of several nodes of Intelligent Cluster of Active Components with programmable, intelligent router which coordinates policy of a delegation task (IRouter component divides tasks and data between active, parallel nodes of ICAC). A unique model of distributed computing used in our system causes that part of calculations prepared (in traditional software model) inside the main thread is parallel and concurrently calculated in separated nodes (machines). All the results are sent back to IRouter which assembles effects of a node's work.

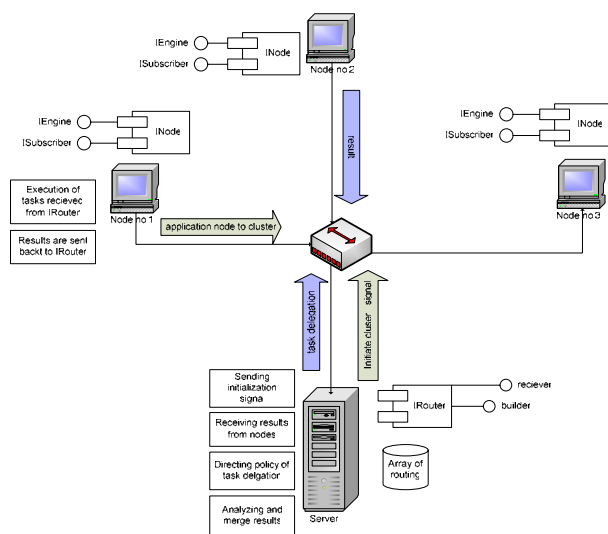

Fig. 1: Draft of ICAC system architecture

3 RESULTS OF EXPERIMENTAL RESEARCH.

The tested system assumed collaboration of one IRouter and two active nodes. ICAC have organized parallel work of application engines on common algorithm – in this case analyse of the power system graph. Increase of computing speed by use of ICAC is reflected in speeding up the process of calculation. Parallel computing executed against shared data structures (in case of this algorithm sets of power nodes and power lines) improved execution of a whole algorithm. And here are the results of researches made in test environment with one IRouter and two active nodes.

Presented results point out that, thanks to use of Intelligent Cluster of Active Components we gain better time execution that means acceleration of algorithm's calculations. Research rendered here introduced the most pessimistic variant – assumption that every time new instance of COM+ objects are created in system operating memory (initialization of cluster). As a result every survey was conducted in the same conditions. The results clearly point out that speed of algorithm execution has been influenced by use of ICAC. The computing power grows about 26% with implementation of our cluster in comparison of algorithm executed in a traditional way (only main thread).

4 CONCLUSIONS

The application of parallel and multithreaded work to analyse some algorithms might in a very intrinsic way accelerate execution process of algorithms. But there are some issues that one have to be aware of. Amount of processors in a system determines effectiveness of multithreaded solutions. If an algorithm using multithreaded mechanism is executed on a single CPU – all benefits flow from using parallel computing might be shattered due to CPU saturation. Improper use of multithreaded computing might lead to decreasing speed of algorithm execution even with comparison to a traditional model with only one thread. The truth is that real benefits from using computing might be noticed only on scalar (multi processor) systems. However an interesting alternative for very expensive multi processor machines is presented in this paper Intelligent Cluster of Active Components, solution which gives end user powerful tool which is scalable and allows to dynamically reconfiguration. Solution which is solid and secure and the most important – can be developed without much effort.

5 REFERENCES

- [1] Baron B., Piątek Ł.: Metody numeryczne w C++Builder, Gliwice Helion 2004, wyd. 1.
- [2] Baron B., Gacek Z.: Medium and High Voltage Overhead Power Lines with Covered Conductors as Sources of the Electromagnetic Field. Monography, Pol. Śl., Gliwice 2006
- [3] Baron B., Pasierbek A., Maciążek M.: Algorytmy numeryczne w Delphi. Helion, Gliwice 2006
- [4] Eddon G.: Programowanie COM+, Microsoft Press 2004, wyd. 1.
- [5] Hormon E.: Programowanie COM w Delphi, Warszawa Translator 2000, wyd. 1.
- [6] Kremens Z, Sobierajski M.: Analiza systemów elektroenergetycznych., Warszawa WNT 1996, wyd. 1.
- [7] Liberty J.: C++ dla każdego, Gliwice Helion 2002, wyd. 1.
- [8] Mueller J.P.: COM+ kompendium programisty, Gliwice Helion 2002, wyd. 1.

Science work funded of ministry means as a research project.

Prof. Bernard Baron, PhD. Eng.

Dr Artur Pasierbek, PhD. Eng.

Mr Tomasz Kraszewski, MSc. Eng.

Silesian University of Technology, Faculty of Electrical Engineering, Institute of Industrial Electrical Engineering and Informatics, ul. Akademicka 10, 44-100 Gliwice, Poland, E-mail: Bernard.Baron@polsl.pl.

Mr Łukasz Osuszek, MSc. Eng.

Silesian University of Technology, Faculty of Automatic Control, Electronics and Computer Science, ul. Akademicka 16, 44-100 Gliwice, Poland, E-mail: Lukasz.Osuszek@architec.pl