

Wireless systems supplying power to electrical devices. Review of the system structures

MICHAŁ FILIPIAK[†], DAMIAN GŁUCHY^{*}

[†]Faculty of Electrical Engineering, Poznan University of Technology, Piotrowo 3A, Poland, michal.filipiak@put.poznan.pl

^{*}Faculty of Electrical Engineering, Poznan University of Technology, Piotrowo 3A, Poland, damian.gluchy@put.poznan.pl

Abstract:

Many electrical and electronic devices, such as mobile phones, music and movie players, computer mice and laptop computers use batteries, which enable them to operate for many hours without being connected to the power system. The variety of equipment requires a multitude of power packs, which must be on hand. Using wireless power supply to charge batteries is an alternative solution. This article presents typical power supply systems based on electromagnetic induction.

Keywords: *wireless power, resonance inverte.*

I. INTRODUCTION

The demand for electronic devices is rising with the development of technologies. Music players, mobile phones, and laptop computers are enjoying greater and greater popularity. Complicated though their structures are in respect of both electronics and computer technologies, these devices have certain features in common. Power supply is one of them, a condition without which they would be worthless. Using these devices in practice requires storing many power packs and cables. An alternative solution is to change wire power supply systems to wireless (contactless) energy transmission ones. This chance is provided the standardisation of mobile-phone chargers adopted at 17th Mobile Word Congress. Automotive industry is another example where the technology is used. Each additional cable in a car poses danger to the driver and the passengers, one of the worst situations being when cables find their way to the car-steering zone. These are the elements of such devices as phones and positioning systems. The computer mouse by the A4tech company is one of the first devices using wireless power supply. Its operation is based on electromagnetic induction. The power of the transmitter is converted into a sinusoidal signal of a specified frequency and transferred to the terminals of the induction coil. Energy is sent to the induction coil of the receiver through alternating magnetic field. Next, it is changed into a voltage of parameters required for energising an electrical system. The benefits of using magnetic fields to transmit energy in such systems include:

- elimination of many cables,
- reduction of the number of chargers
- using a device without connecting it to a charger.

In addition to good features, this solution also has some drawbacks resulting from the use of magnetic field:

- loss of electric energy during transmission,
- short range (yet, with the support of research, new devices are being developed, providing better performance),

- additional costs of installing energy-using elements in devices (coils, antennas, etc),
- a larger number of electronic elements, especially in industrial devices, necessitates additional overhauls,
- increasing the likelihood of failure and interference,
- increasing the effect that magnetic fields have on living organisms,
- the failure of a transmitter will cut off power supply from many devices

II. STRUCTURE AND THE PRINCIPLE OF OPERATION

Wireless energy transmission consists in using electromagnetic induction operating on the principle of back coupling. A system of such a type features a transmitter generating signals changing in time of a frequency of 1 kHz to a few MHz. To minimize energy loss, all systems operate with a resonant frequency. Voltage is conveyed from the transmitter to the terminals of the air-core transformer. As a result of the alternating of current passage, the coil of the primary winding generates alternating magnetic field, which induces electromotive force in the secondary winding. The alternating voltage at the transformer output requires the use of a rectifier system and filters if it is intended to be used to energise electronic devices.

Figure 1 presents a block diagram of a typical wireless power supply system

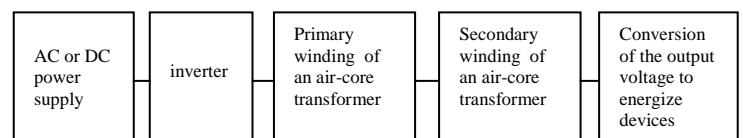

Fig.1 Block diagram of wireless power supply [1]

A contactless power supply system may be energised by both direct and alternating voltage sources. When the direct voltage is used, a DC-AC inverter should be installed first. Alternating voltage requires an AC-AC inverter. It is possible to specify the frequency of a system by using an inverter. Figure 2 presents a half-bridge series resonant inverter, which is particularly fit for the direct voltage power supply. Using half of the energizing voltage as it does, the inverter is suitable for the devices of small and medium power.

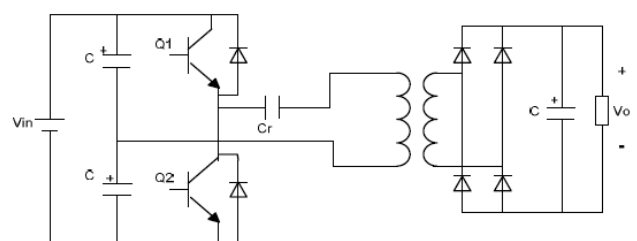

Figure.2 Half-bridge series resonant inverter [2]

Figure 3 presents a full-bridge series resonant inverter. It is more difficult to control, but it can be used to transmit larger power.

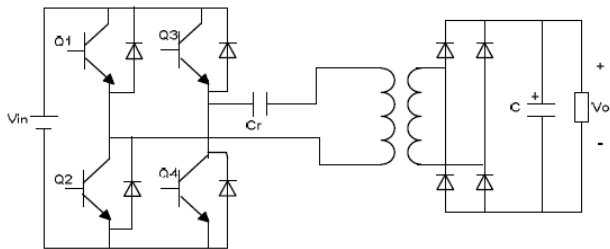

Figure.3 Full-bridge series resonance inverter [3]

A signal converted in this way is conveyed to an air-core transformer. Two coils with properly arranged windings can be the air-core transformer, one being located in the transmitter and the other in the receiver, namely any device energised by direct or alternating voltage.

IV. SYSTEM EFFICIENCY

The transmission of energy does not need any galvanic connections, a feature that has certain limitations. Electromagnetic induction enables energy to be transmitted from specified distances. Widening the air-gap between the coils of a system consisting of a transmitter and a receiver weakens its efficiency. It will act like a coreless transformer. The efficiency dwindles because the leakage flux grows as the gap becomes larger. This results from the decrease in the coupling level of the transformer's coils. One of the ways of extending the energy-transmission distance is to raise the power supply voltage, a procedure that induces a larger electromagnetic flux in the transmitter coil to supply enough power to the receiver. A large energy loss, resulting from increasing a leakage flux, is a drawback of this solution, meaning that the leakage of the inductance of the transformer's windings will also rise. Moreover, the permissible standards of electromagnetic compatibility can be exceeded. Another possibility is to bring about resonance in the system. This is achieved by the connecting of a capacitor to a system in series or in parallel. A capacitor used in the system performs a compensation function and decreases the impedance of the circuit.

Figure 4 presents a diagram of series as well as series and parallel compensation systems.

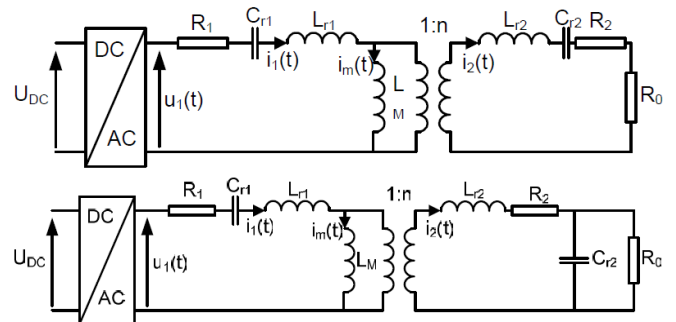

Fig. 4 Diagram of a) series, and b) series and parallel compensation systems [4]

The difference between the way in which the systems in figure 4 operate is that while a capacitor for the series compensation element is selected on a one-off basis, in the case of the series and parallel compensation, the capacitor value depends on the coupling co-efficient and has to be determined each time.

V. CONCLUSIONS

Wireless power supply technologies bring many benefits into everyday life. Unfortunately, the systems used currently are not efficient enough and have a limited range of operation. Though the introduction of these solutions will undoubtedly contribute to the reduction of cables and power packs, it may also cause problems, such as frequent failures. The use of wireless energy transmission in automotive industry may make people become more interested in electrical cars which could cover unlimited distances while operating on battery energy. The observation of the development trends concerning wireless power supply shows that technical parameters are being successively improved.

REFERENCES

- [1] Kuen-Cheng Wang, Che-Wei Hsu Tung- Jung Chan Tsung-Shih Chien Tsair-Rong Chen *Study of Applying Contactless Power Transmission System to Battery Charge Power Electronics and Drive Systems*, 2009. PEDS 2009. International Conference on (PEDS2009) Publication Year: 2009 , Page(s): 257 – 262 (page 257)
- [2] Du Guiping, Li Xiongtao, Sheng Songtao *Modeling and Simulation of Contactless Power Transmission System by Inductance Coupling* ISIEA 2009, page. 123
- [3] Du Guiping, Li Xiongtao, Sheng Songtao *Modeling and Simulation of Contactless Power Transmission System by Inductance Coupling* ISIEA 2009 page. 123
- [4] Moradewicz A., Miśkiewicz R. *Systemy bezstykowego zasilania komputerów przenośnych* PRACE INSTYTUTU ELEKTROTECHNIKI, booklet 236, 2008 page 51
- [5] Moradewicz A. *System zasilania bezprzewodowego z rezonansowym przekształtnikiem szeregowym* PRACE INSTYTUTU ELEKTROTECHNIKI, booklet 231, 2007