

Reconfigurable First-Order Filter Operating with Non-Ideal Parameters of Active Elements

T. Zak, R. Sotner, J. Jerabek, K. Vrba
Faculty of Electrical Engineering and
Communication
Brno University of Technology
Brno, Czech Republic
sotner@feec.vutbr.cz

T. Dostal
Dept. of Electrical Engineering and Computer
Science
College of Polytechnics Jihlava
Jihlava, Czech Republic
tomas.dostal@vspj.cz

Abstract – This contribution presents a way to improve the finite attenuation in the stop band in the case of a particular transfer function of the specific filtering structure. It is an important problem in the field of active filters. A real non-ideal model (including small-signal parasitic influences caused by real active elements) of the electronically reconfigurable reconnection-less filter is studied in configuration when the most affected transfer function is used (high-pass response in our case). Symbolical analyses of ideal and influenced transfer function and sensitivity analyses in Matlab provide information on how to improve the level of stop-band attenuation by available parameters even under conditions of really unsuitable terminal resistances (output resistances) of active elements used.

Keywords – Active filter; electronic control; finite stop-band attenuation; real behavior; reconfigurable transfer function; small-signal modeling

I. INTRODUCTION

Filters are very useful function blocks for analog signal processing. There are many different variants and conceptions [1]. Active filters [2], [3] create a very important group. Utilization of suitable active elements allows many useful features in filtering applications e.g. amplification (gain) or electronic control of parameters of the filter (pole frequency, quality factor, bandwidth, pass-band gain, zero frequency, attenuation control, reconfiguration, etc.). However, due to the presence of an active device with real features (real terminal impedances, gain and tracking errors, frequency dependent parameters, temperature dependence and fabrication mismatch), active filters suffer from many and various drawbacks. A very significant problem of active filtering circuits in voltage and current-mode [4] of operation is the finite attenuation in stop bands. This problem is caused by real small-signal (linear operation of the whole system is supposed) parameters of real active elements in the filtering structure. These parameters represent terminal impedances of active devices (input and output

resistances, capacitances, inductances in the most cases).

So-called multifunctional or universal filtering structures (they allow several types of transfer characteristic simultaneously), for example [5]–[8], have many drawbacks caused by these effects in real case. The most significant problems occur in the case of these transfer functions: high-pass (HP), band-reject and band-pass, as has been shown in many recent works [9]–[12]. But it depends on the particular filtering structure. Work [9] shows that also other transfer functions (namely low-pass response) may be affected.

We present an example of the first-order electronically reconfigurable filtering structure (type of the transfer can be changed electronically without reconnection of the input and output port) where HP response is available, among other transfer types, and real small-signal parameters of active devices have the most influencing impact. Therefore, we focused our attention on this transfer function. As the first step, we analyzed the transfer function (magnitude response) extended by parasitic parameters and found limits of the stop-band attenuation (function for limit value of attenuation). Then we provided sensitivity analysis of the transfer function on active and passive parameters of the circuit to see which parameters influence the most real stop-band transfer of the HP response. At the end, a possible way of the improvement of the maximal achievable attenuation of the HP response was analyzed in several scenarios (under different critical conditions).

II. INITIAL PROBLEM – PARTICULAR FILTERING STRUCTURE

Problems with finite attenuation in stop-band can be found in many various types and structures of active multifunctional filters. We provided an example of the first-order filtering structure with special features. Transfer functions are not accessible simultaneously from different outputs (as commonly available for example in [5]–[12]) but particular transfers are reconfigurable electronically [13]–[17] by parameters of the active element used. The filter in Fig. 1 employs a current follower/inverter (CF/I), adjustable current amplifier (CA), transconductance amplifier (OTA) and three passive elements (R_f , R_L , C). Transconductance (g_m) and current gain (B) are adjustable electronically. Figure 1 includes also the

Research described in this paper was financed by the Czech Ministry of Education in the frame of the National Sustainability Program under grant LO1401. For research, infrastructure of the SIX Center was used. Research described in the paper was supported by the Czech Science Foundation project under No. 14-24186P. Grant No. FEKT-S-14-2281 also supported this research. The support of the project CZ.1.07/2.3.00/20.0007 WICOMT, financed from the operational program Education for competitiveness, is gratefully acknowledged.

most important small-signal parasitic elements caused by real terminal features of active elements. Transfer function has ideal form (without consideration of R_{p1} , C_{p1} , C_{p2} in this stage):

$$K(s) = \frac{g_m R_L}{R_f} \left(\frac{2 - B + sCR_f}{g_m + sC} \right). \quad (1)$$

Following text assumes $g_m = 1/R_f$ and $R_L = R_f$ for unity pass-band gain. $B = 1$ gives direct transfer response (constant unity magnitude and phase equal to 0 degrees). The HP response is obtained in case of $B = 2$ and the inverting all-pass response is available for $B = 3$.

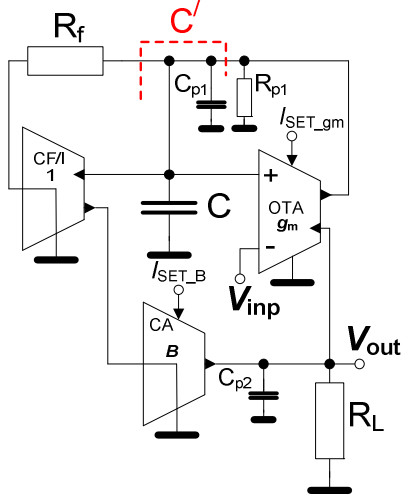

Figure 1. First-order filtering structure allowing electronic reconfigurability of the transfer function type.

Supposing an ideal situation, we designed circuit with following parameters: $R_f = R_L = 1 \text{ k}\Omega$, $C = 470 \text{ pF}$, $g_m = 1 \text{ mS}$ and $B = 2$ (for HP response).

III. ANALYSIS OF PARASITIC EFFECTS IN HP CONFIGURATION

The high-pass response is the most affected transfer function (by small-signal parasitic elements) of the circuit structure (Fig. 1). Extended form of the transfer function is available if real small-signal influences (mentioned before and included in Fig. 1) are considered as follows:

$$K'(s) = g_m R_L \frac{N'(s)}{D'(s)}, \quad (2)$$

where

$$N'(s) = R_{p1}(2 - B) + R_f + sC'R_f R_{p1}, \quad (3)$$

$$D'(s) = g_m R_f R_{p1} + R_f + s[R_f R_{p1} C' + R_L C_{p2}(g_m R_f R_{p1} + 2R_{p1} + R_f)] + s^2 C' C_{p2} R_f R_{p1} R_L. \quad (4)$$

We suppose the following simplifications: $R_{outCF/1} \gg R_{inpCA}$, $R_{outOTA} \gg R_L$, because they are commonly fulfilled. Therefore, we can suppose R_L in node as dominant resistance. Small-signal parameters of active devices are expected as follows: $R_{p1} \approx R_z \parallel R_{x+}$

$= 1 \text{ M}\Omega$, $C_{p1} = C_f + C_z + C_{x+} \ll C$ and $C_{p2} = C_{outCA} + C_{x-} = 1 \text{ pF}$. Direct influence of real features on stop-band gain of the HP can be observed in Fig. 2 where magnitude and phase response is depicted. The influenced model in Fig. 1 has character of the second-order circuit, therefore the second pole appears at high frequencies (above 100 MHz). We can evaluate limit transfer in this stop-band by:

$$K_{\min} = \lim_{\omega \rightarrow 0} |K'(s)| = \frac{R_L g_m [R_f + R_{p1}(2 - B)]}{R_f (R_{p1} g_m + 1)}, \quad (5)$$

that leads to numerical value $K_{\min} = -60 \text{ dB}$ instead of infinite attenuation expected theoretically. Note that capacitances are not important for K_{\min} value.

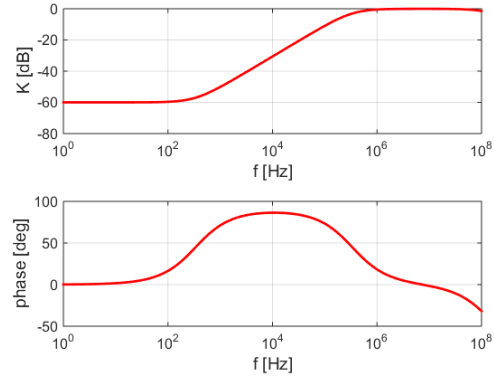

Figure 2. HP response: resulting magnitude and phase characteristics for non-ideal situation regarding discussed parasitic small-signal parameters.

IV. SENSITIVITY ANALYSIS – SIGNIFICANT PARAMETERS

It is really important to reveal effect of real-circuit parameters on the HP transfer function. Sensitivity analysis of the transfer function on particular parameters can provide such information. From (5) it is obvious that for K_{\min} value, our analysis reduces only to R_f , R_L and R_{p1} impact on the HP transfer function (influenced HP). Relative sensitivity of transfer function (impact on magnitude response) on each parameter was studied in Matlab, see Fig. 3 (also result for g_m parameter are included, but it has not impact on stop-band gain). This simulation confirms expected behavior. Sensitivity analysis offers a view on particular impact of all important parameters on low frequency band. The most important impact on HP stop-band transfer has R_{p1} (except R_L), i.e. function of the filter in the pass-band seems to be influenced minimally by this parameter. Other small-signal parameters may cause impact on other useful features of the filter (pass-band gain, pole frequency, parasitic zero frequency). Therefore, we cannot adjust them. Value of R_{p1} seems to be only one possibility how to increase the stop-band attenuation. However, this parameter is given by producer of active elements (design specifications, used internal topology and structure of active device, specific technology, etc.) and it is not possible to influence this value. This parameter is not very favorable in many cases (see for example OPA860 [18], MAX435 [19]) - real values of resistances are extremely low in some cases (tens, even units of $\text{k}\Omega$). However, there seems to exist a

better solution. We can use B that normally solves for electronic transfer reconfiguration (discontinuous change of the value). However, when non-ideal parameters are considered (low R_{p1}), it can also serve for stop-band attenuation control. The B adjusting causes HP with zero, see fundamental ideal transfer (1). Fortunately, this possibility remains also if real non-ideal features are taken into account (2).

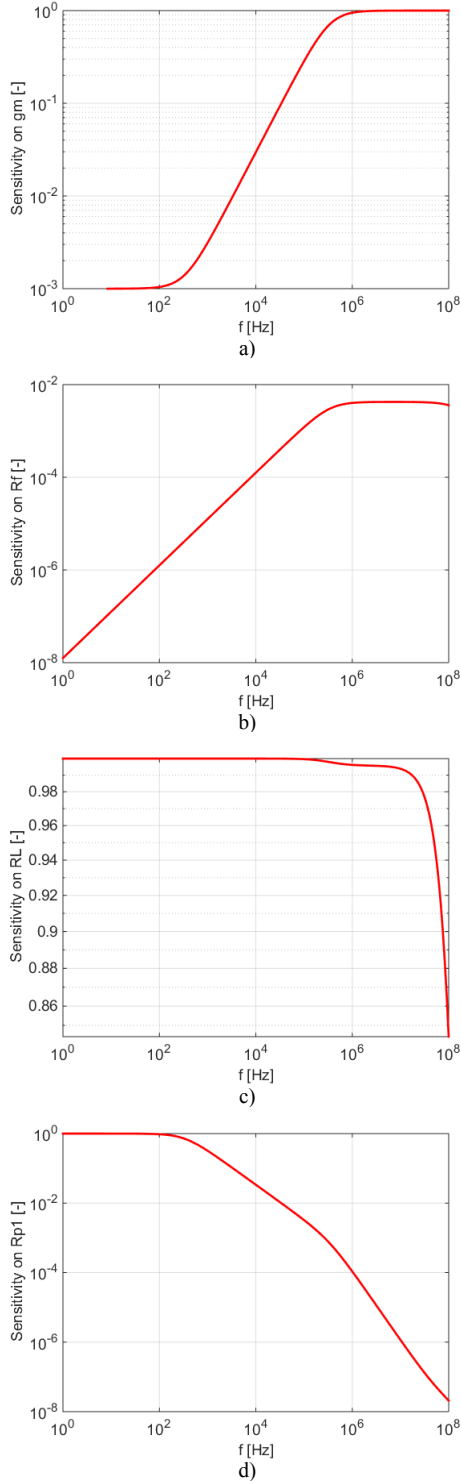

Figure 3. Sensitivity functions (magnitude) of transfer response configured as HP on particular parameters: a) g_m , b) R_f , c) R_L , d) R_{p1} .

V. IMPROVEMENT OF STOP-BAND ATTENUATION OF HP

Of course, magnitude response in stop-band of the HP function is very sensitive on B change, see Fig. 4 (parameters are taken from section 2, except R_{p1}). Direct impact of the R_{p1} on HP magnitude response is depicted in Fig. 5. However, sensitivity on B depends on other parameters (especially R_{p1}). Minimal stop-band transfer (maximal attenuation) given by (5) can be expressed graphically. Dependence of stop-band transfer of the HP on B (while R_{p1} is stepped) is shown in Fig. 6. Figure 7 shows particular effect of B adjusting for two particular R_{p1} values ($R_{p1} = 1 \text{ M}\Omega$ in Fig. 7a and $R_{p1} = 10 \text{ k}\Omega$ in Fig. 7b). Low values of R_{p1} are quite common value in the case of high-impedance terminals of some CMOS solutions of operational transconductance amplifiers, current conveyors, etc. [20].

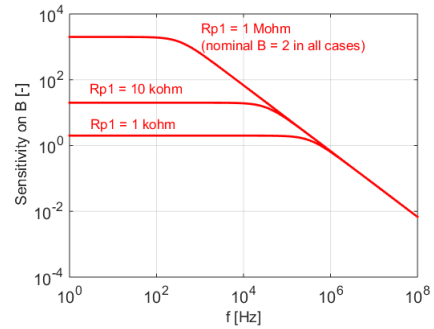

Figure 4. Sensitivity function (magnitude) of transfer response configured as HP on B (for three values of R_{p1}).

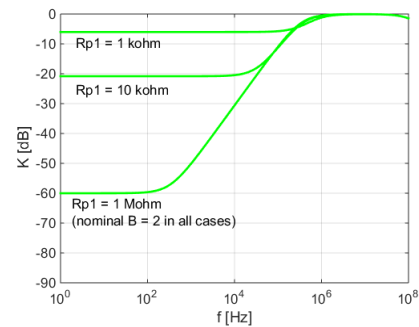

Figure 5. Impact of R_{p1} stepping on stop-band attenuation.

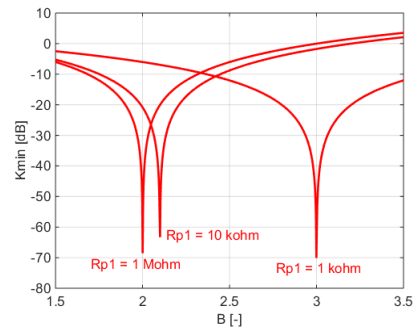

Figure 6. Dependence of minimal stop-band transfer on B for three values of R_{p1} .

We can see that local minimum of the HP transfer migrate for stepping of the R_{p1} . When $R_{p1} = 1 \text{ M}\Omega$ (Fig. 7a), values of B has to be really very close to ideal proposal ($B = 2$) and due to the high sensitivity (obvious from Fig. 7a), it can be difficult to find exact

minimum. Note that if $R_{p1} = 10 \text{ k}\Omega$, $B \cong 2.1$ is required, and $B \cong 3$ is necessary for $R_{p1} = 1 \text{ k}\Omega$. Relative sensitivity of magnitude of the HP transfer function in stop band on B decreases with decreasing R_{p1} (Fig. 4). Impact of small inaccuracy of B has not so extreme effect (Fig. 7b) in this particular case. In other words – for small inaccuracy of B , sufficient attenuation in stop band is obtained.

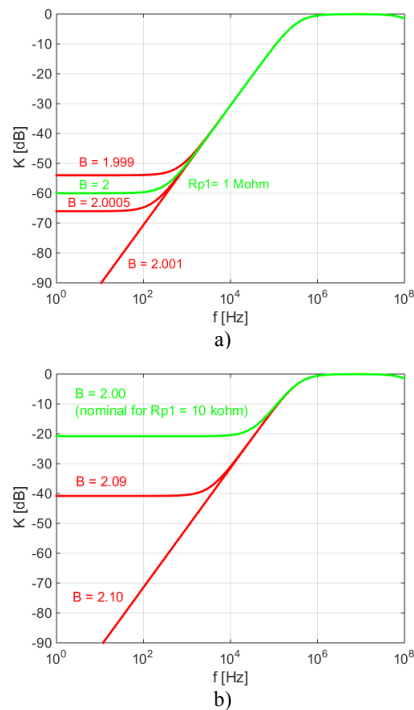

Figure 7. Magnitude response of HP influenced by B adjusting (impact of R_{p1} value on sensitivity of K_{\min} adjusting by B) for: a) $R_{p1} = 1 \text{ M}\Omega$, b) $R_{p1} = 10 \text{ k}\Omega$.

VI. CONCLUSION

We proved in this work that electronic reconfigurability can serve not only for intentional transfer type reconfiguration, but also for improving of particular parameter of filtering function in extremely unsuitable conditions. If not solved properly, it leads to inapplicability of the filter in practice. Plenty of research works regarding active filtering structures, having this issue, were published in the past. Presented filtering structure brings possibility how to suppress problems with finite attenuation in the stop band and simultaneously offers reconfigurability of the type of the transfer function between high-pass, inverting all-pass and direct transfer type (it was not analyzed in this paper). Sensitivity of the stop-band attenuation on B is dependent on particular value of R_{p1} , therefore precise and accurate setting (followed probably by some type of auto-compensation technique for really reliable purposes) is required to obtain sufficiently high attenuation. Note that presented results are valid for this particular circuit, presented in this paper, and it cannot be generalized.

REFERENCES

[1] W. Chen, "The Circuits and Filters Handbook," Boca Raton, FL: CRC Press, 2002.

[2] T. Deliyannis, Y. Sun, J. K. Fidler, Continuous-Time Active Filter Design. Boca Raton, CRC Press, 1999.

[3] R. Raut, M. N. S. Swamy, Modern Analog Filter Analysis and Design: A practical approach. Weinheim, Wiley, 2010.

[4] C. Toumazou, E. J. Lidgley, D. G. Haigh, Analogue IC design: The current mode approach. London: P. Peregrinus Ltd., 1990.

[5] Y. Sun, J. K. Fidler, "Some design methods of OTA-C and CCI-RC filters," in Proc. IEE Colloquium on Digital and Analogue Filters and Filtering, pp. 1-8, 1993.

[6] Y. Sun, J. K. Fidler, "Current-mode OTA-C realization of arbitrary filter characteristics," Electr. Letters, vol. 32, no. 13, pp. 1181-1182, 1996.

[7] Y. Sun, J. K. Fidler, "Current-mode multiple-loop feedback filters using dual output OTAs and grounded capacitors," International Journal of Circuit Theory and Applications, vol. 25, no. 2, pp. 69-80, 1997.

[8] T. Dostal, "Filters with Multi-Loop Feedback Structure in Current Mode," Radioengineering, vol. 12, no. 3, pp. 6-11, 2003.

[9] R. Sotner, J. Slezak, T. Dostal, "Influence of mirroring of current output responses through grounded passive elements," in Proc. 20th International Conference Radioelektronika 2010, pp. 1-4, 2010.

[10] R. Sotner, J. Petrzela, J. Slezak, "Current-Controlled Current-Mode Universal Biquad Employing Multi-Output Transconductors," Radioengineering, vol. 18, no. 3, pp. 285-294, 2009.

[11] J. Jerabek, R. Sotner, K. Vrba, "Tunable universal filter with current follower and transconductance amplifiers and study of parasitic influences," Journal of Electrical Engineering, vol. 62, no. 6, pp. 317-326, 2011.

[12] J. Jerabek, R. Sotner, Z. Kincl, T. Dostal, K. Vrba, "Study of practical problems in two-loop CCTA based biquad: Finite attenuations in stop bands," in Proc. 8th International Conference on Electrical and Electronics Engineering (ELECO2013), pp. 40-44, 2013.

[13] J. Petrzela, R. Sotner, "Systematic design procedure towards reconfigurable first-order filters," in Proc. 24th International Conference Radioelektronika 2014, pp. 237-240, 2014.

[14] R. Sotner, J. Jerabek, N. Herencsar, R. Prokop, K. Vrba, T. Dostal, "Resistor-less First-Order Filter Design with Electronical Reconfiguration of its Transfer Function," in Proc. 24th International Conference Radioelektronika 2014, pp. 63-66, 2014.

[15] R. Sotner, N. Herencsar, J. Jerabek, R. Prokop, A. Kartci, T. Dostal, K. Vrba, "Z-Copy Controlled-Gain Voltage Differencing Current Conveyor: Advanced Possibilities in Direct Electronic Control of First-Order Filter," Elektronika Ir Elektrotechnika, vol. 20, no. 6, pp. 77-83, 2014.

[16] R. Sotner, J. Jerabek, B. Sevcik, T. Dostal, K. Vrba, "Novel Solution of Notch/All-pass Filter with Special Electronic Adjusting of Attenuation in the Stop Band," Elektronika Ir Elektrotechnika, vol. 17, no. 7, p. 37-42, 2011.

[17] R. Sotner, J. Jerabek, J. Petrzela, K. Vrba, T. Dostal, "Design of Fully Adjustable Solution of Band-Reject/All-Pass Filter Transfer Function Using Signal Flow Graph Approach," in Proc. 24th International Conference Radioelektronika 2014, pp. 67-70, 2014.

[18] Texas Instruments. OPA860 Wide-bandwidth, operational transconductance amplifier (OTA) and buffer (datasheet), 2008, 33 p., accessible on [www: http://www.ti.com/lit/ds/symlink/opa860.pdf](http://www.ti.com/lit/ds/symlink/opa860.pdf)

[19] Maxim Integrated, MAX435/436 Wideband Transconductance Amplifiers (datasheet), 1993, 17 p., accessible on [www: http://datasheets.maximintegrated.com/en/ds/MAX435-MAX436.pdf](http://datasheets.maximintegrated.com/en/ds/MAX435-MAX436.pdf)

[20] D. Biolkova, R. Senani, V. Biolkova, Z. Kolka, "Active elements for analog signal processing: Classification, Review and New Proposals," Radioengineering, vol. 17, no. 4, pp. 15-32, 2008.