

# A Novel Soft-Switching Bidirectional DC-DC Converter for Energy Storage Applications

Venkata Subba Rao Yanna<sup>1</sup>, V.V.Subrahmanya Kumar Bhajana<sup>1,2</sup>, Pavel Drabek<sup>2</sup>  
Madhuchandra Popuri<sup>3</sup>

<sup>1</sup>School of Electronics Engineering, KIIT University, Bhubaneswar, India

<sup>2</sup>Regional Innovation Centre for Electrical Engineering, University of West Bohemia, Pilsen, Czech Republic

<sup>3</sup>School of Electrical Engineering, KIIT University, Bhubaneswar, India

venkata.yanna@gmail.com, kumarbvv@rice.zcu.cz, bvvs.kumarfet@kiit.ac.in,  
drabek@ieee.org, madhuflo@gmail.com

**Abstract** – In this paper, a soft-switching bidirectional DC-DC converter is proposed. In order to achieve soft-switching conditions ZVS turn on / ZCS turn off, the auxiliary circuit including a switch, a capacitor, a diode and a small inductor are adapted to the bidirectional converter. The soft-switching characteristics in this converter are achieved regardless of power transfer. Due to the existence of auxiliary circuit, the switching losses are reduced and thus improve the overall efficiency. The switching devices achieved ZVS turn on and ZCS turn off operations, while converter operated in boost and buck modes, respectively. The operating principles are described and verify the soft-switching characteristics by its simulation analysis. The proposed converter system 100V/340V/650W is validated by simulation analysis.

**Keywords**–Bidirectional converter; Non-isolated converter; Soft-switching; zero voltage switching(ZVS); zero current switching (ZCS)

## I. INTRODUCTION

In recent trends, the tradition of non-isolated bidirectional converter is widely being used in the applications such as battery operated vehicles, uninterrupted power supplies, renewable energy conversion systems and in many industrial applications. In order to reduce the ripple input current and to achieve zero voltage switching (ZVS) in a non-isolated bidirectional converter [1], an auxiliary winding and auxiliary inductors were adapted with a conventional bidirectional cell (CBC). Though the soft-switching is obtained, this converter can only operate at a very low output powers. In a similar way, a small inductor and two capacitors were used in addition with CBC [2]. ZVS condition is achieved for all switches but it may not withstand for high power applications. On the other hand, in order to increase voltage conversion ratio or high gain and also to reduce voltage stresses, an integrated DC transformer [3] has been added to CBC. Furthermore, by including coupled inductor as a part of high step-up/step-down converter [4] to enhance the conversion ratio and to achieve ZVS conditions, as well. Then, apart from

achieving the soft-switching, the overall efficiency is another key factor to improve the performance of a non-isolated converter. By incorporating active snubber cells [5-6] to a CBC, the ZVS operation is obtained. These converters have better efficiency, though these lossless active snubbers may increase the volume and cost. There are many zero voltage transition bidirectional converters [7] that are proposed with auxiliary circuit, which comprises of two auxiliary switches and a capacitor connected via magnetic coupling. As a result, the soft-switching is achieved while ensuring better efficiency. In the same way, another ZVT BDCs are proposed with several possible combinations [8] which are added with auxiliary switches and snubber capacitors that are associated through magnetic coupling. However, all the converters in [7-8] require additional switches and capacitors except the resonant inductors. Recently, the researchers are focusing on utilization of active snubber circuits in a multiport bidirectional converter have been reported [9-10] which curtail the input current ripples and operate through soft-switching. Rather than obtaining soft-switching, usage of magnetic coupling and auxiliary switches, a two winding transformer as a part of auxiliary cells are taken into account for a non-isolated bidirectional converter [11] implemented with Si MOSFETs and then presently, the researchers are focusing on impact of SiC MOSFETs [12] on non-isolated BDC, which can increase the output power levels and soft-switching can be obtain by utilization the coupled inductor and active snubber circuits. Although, SiC devices are an effective solution, the overall cost of the converter may more than the conventional Si IGBT or Si MOSFET based converters.

This paper presents a new design of non-isolated BDC with a simple auxiliary circuit. The efficiency and soft-switching are the key benefits of the proposed converter without increasing additional losses. In order to validate the soft-switching characteristics, the proposed converter system with 100V-340V-600W has been evaluated by its simulations analysis. This paper is organized as follows: section II describes the proposed circuit and its operation principles. Section III represents the simulation analysis.

This research has been supported by the Ministry of Education, Youth and Sports of the Czech Republic under the project OP VVV Electrical Engineering Technologies with High-Level of Embedded Intelligence CZ.02.1.01/0.0/0.0/18\_069/0009855 and project No. SGS-2018-009

## II. DESCRIPTION AND ITS OPERATION PRINCIPLES OF A NEW ZVS BIDIRECTIONAL CONVERTER

The circuit diagram of the proposed ZVS Bidirectional converter is shown in Fig.1. The main bidirectional cell adopted with a single auxiliary resonant circuit is also shown. The bidirectional cell comprises of two main switches  $S_1$ ,  $S_2$  and an input inductor  $L$ . The auxiliary resonant circuit consists of a switch  $S_r$ , a capacitor  $C_r$ , a diode  $D_r$  and an inductor  $L_r$ . Fig.2 (a,b) shows the equivalent schematics of boost and buck modes. The operation of proposed converter is described separately with the help of steady state waveform shown in Fig.3 and Fig.5. The boost mode operation is divided into seven intervals and its equivalent schematics with current flow are shown in Fig.4 (a,b,c,d,e).

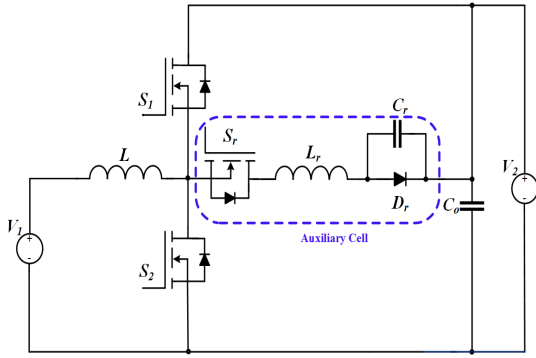

Figure 1. Proposed soft-switching bidirectional converter

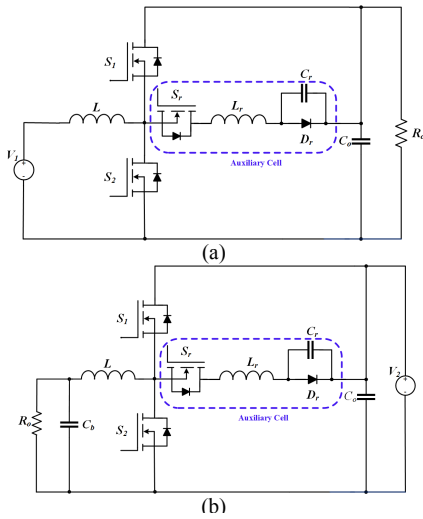

Figure 2. Equivalent circuit (a) Boost mode (b) Buck mode

### A. Operation Principles: Boost mode

Interval ( $t_0-t_1$ ): This interval begins when  $S_r$  turns on. The  $L_r$  current linearly increases to the level of input current and  $C_r$  begins to charge, since  $L_r$  and  $C_r$  are resonating with each other.

Interval ( $t_1-t_2$ ): At  $t_1$ , the  $S_1$  is turned on, the voltage across  $S_1$  is zero and body diode of  $S_1$  starts conducting, thus the ZVS turn on achieved for  $S_1$ . After quarter cycle of this interval, the body diode of  $S_r$  starts conducting. At  $t_2$ , the current through  $L_r$

linearly decreases,  $C_r$  continues to charge and the body diode stops conducting.

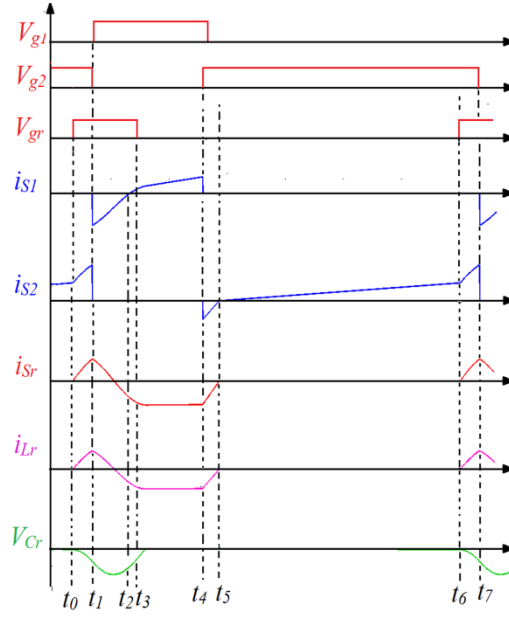

Figure 3. Steady State waveforms : Boost mode

Interval ( $t_2-t_3$ ): This is a short interval, the body diode of  $S_r$  will still conducting and  $S_1$  current reaches to input current level  $I_{in}$ . The current through  $L_r$  and voltage across  $C_r$  remains same.

Interval ( $t_3-t_4$ ): This interval begins when  $S_r$  is turned off and  $S_1$  is still conducting. During this interval, the voltage across  $C_r$  and  $L_r$  continue to remain same.

Interval ( $t_4-t_5$ ): This interval begins when  $S_1$  is turned off and  $S_2$  is turned on. During this interval,  $S_1$  body diode conducts to allow the resonant current  $i_{Lr}$ . At the end of this interval,  $i_{Lr}$  reduces to zero and body diode of  $S_r$  stops conducting.

Interval ( $t_5-t_6$ ): Throughout this interval,  $S_2$  will be conducting and energy will be accumulated by input inductor,  $L$  via  $V_1-L-S_2$ .

Interval ( $t_6-t_7$ ): This interval is same as the interval,  $t_0-t_1$ .

### B. Operation Principles: Buck mode

Interval ( $t_0-t_1$ ): This interval begins when the  $S_r$  is turned on. Due to  $S_r$  turning on, the ZVS turn on will be obtained for  $S_1$  and ZCS turn off for  $S_2$ . The  $L_r$  current linearly increases to the level of input current and  $C_r$  starts charging, since  $L_r$ ,  $C_r$  are resonating with each other. The body diode of  $S_1$  continues to conduct and allow the resonant current.

Interval ( $t_1-t_2$ ): At  $t_1$ , the voltage across  $S_1$  becomes zero and body diode of  $S_1$  starts conducting, thus the ZVS turn on achieved for  $S_1$ . At the end  $t_2$ , the current through  $L_r$  reaches smoothly to zero and voltage across  $C_r$  is maintained at  $-V_{in}$ . Therefore, the body diode stops conducting.

Interval ( $t_2-t_3$ ): This interval begins when the  $S_r$  is turned off.  $S_1$  current linearly increases, and it reaches to the level of input current at  $t_3$  and at same time, the

$L_r$  current is maintained at  $-I_m$  and  $C_r$  discharges completely

power; 600 W;  $L_r=10\mu\text{H}$ ;  $C_r = 50 \text{ nF}$ ; Output capacitor

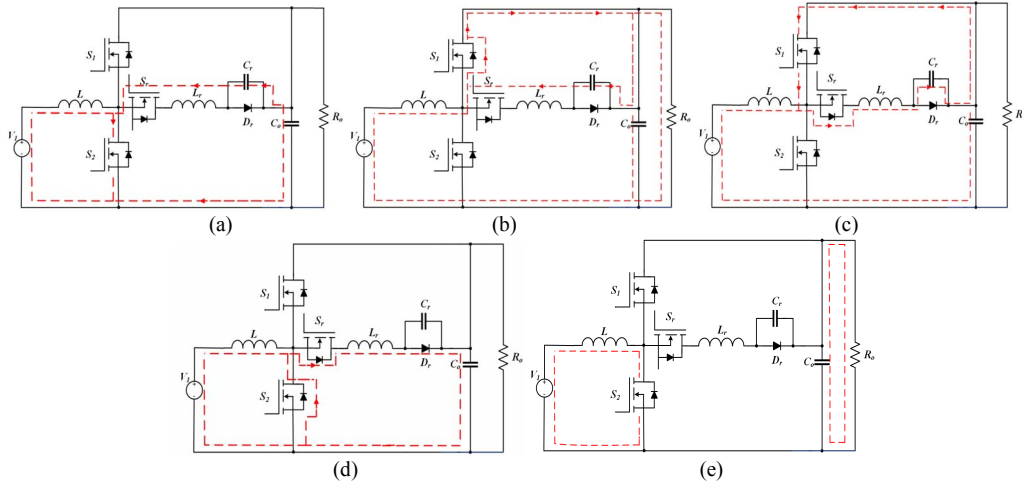

Figure.4 Equivalent current flow schematics (a) Interval  $(t_0-t_1)$  (b) Interval  $(t_1-t_2)$  (c) Interval  $(t_2-t_3)$  &  $(t_3-t_4)$  (d) Interval  $(t_4-t_5)$  (e) Interval  $(t_5-t_6)$  : Boost mode

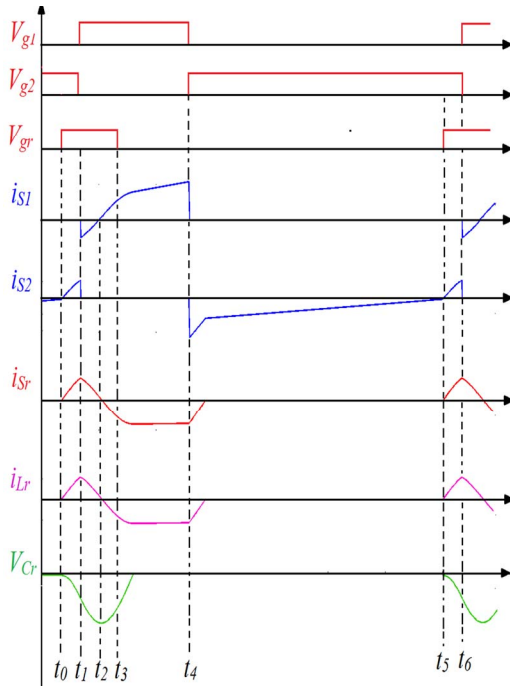

Figure 5. Steady State waveforms : Buck mode

Interval  $(t_3-t_4)$ : During this interval,  $S_1$  and body diode of  $S_r$  are in conducting state. The  $i_{Lr}$  and  $V_{Cr}$  are constant.

Interval  $(t_4-t_5)$ : This interval starts when  $S_2$  is turned on. A resonant peak appears at starting of this interval, at  $t_4$ , value is that of input current. During this interval, energy is accumulated by the input inductor,  $L$ .

Interval  $(t_5-t_6)$ : This interval is same as the  $t_0-t_1$  interval.

### III. SIMULATION ANALYSIS

The proposed bidirectional converter designs and simulations are performed on MATLAB Simulink. The parameters considered for the simulation analysis is as follows:  $V_1=100\text{V}$  (Boost mode)  $V_2=340\text{V}$  (Buck mode); Switching frequency,  $f_{sw}= 50 \text{ kHz}$ ; Output

For boost and buck modes of operations, the duty cycles used for  $S_1$  is 0.28 and  $S_2$  is 0.7. The duty cycle for the auxiliary switch,  $S_r$  is 0.12. Simulations are performed separately for both boost and buck modes. The voltage and current waveforms of  $S_1$ ,  $S_2$  and  $S_r$  in boost mode are shown in Fig.6 (a,b,c,d,e,f). It can be seen that, ZVS turn on is obtained for  $S_1$  and  $S_2$ . The auxiliary switch  $S_r$  is turned off with zero current switching operation. Fig.7 (a,b,c) show the waveforms of  $L_r$ ,  $C_r$  and  $D_r$ . Similarly, simulations are performed for buck mode by considering input voltage ( $V_2$ ) 340 V and output voltage ( $V_o$ ) obtained is 100 V. The voltage and current waveforms of  $S_1$ ,  $S_2$  and  $S_r$  shown in Fig.8 (a,b,c,d,e,f). It is observed from these results, that  $S_2$  is turned off with zero current switching condition and  $S_1$  is turned on with ZVS condition. The  $L_r$ ,  $C_r$  and  $D_r$  waveforms are shown in Fig.9 (a,b,c).

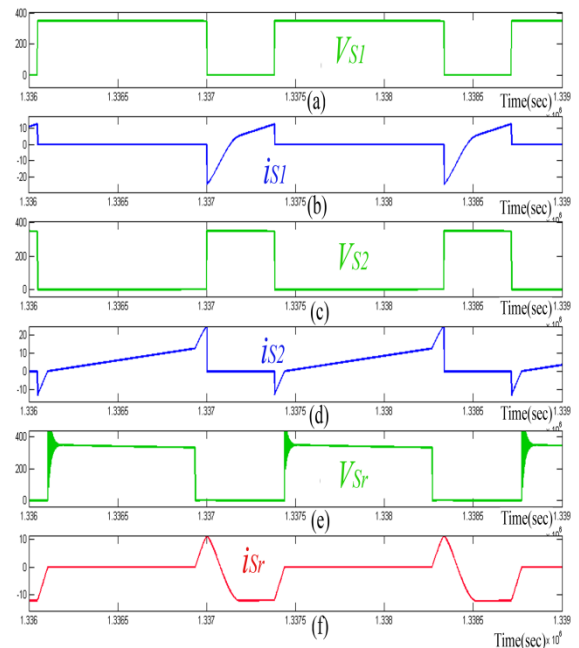

Figure.6 Boost mode Simulated waveforms (a)  $V_{S1}$  (b)  $V_{S2}$  (c)  $i_{S1}$  (d)  $i_{S2}$  (e)  $V_{Sr}$  (f)  $i_{Sr}$

The soft-switching operation is clearly observed with varying the duty cycle for  $S_r$ , 0.08 and 0.12. The clear transitions of  $S_1$ ,  $S_2$  are shown in Fig.10(a,b,c).

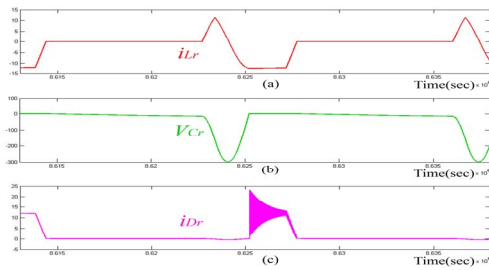

Figure 7. Boost mode Simulated waveforms (a)  $i_{Lr}$  (b)  $V_{Cr}$  (c)  $i_{Dr}$

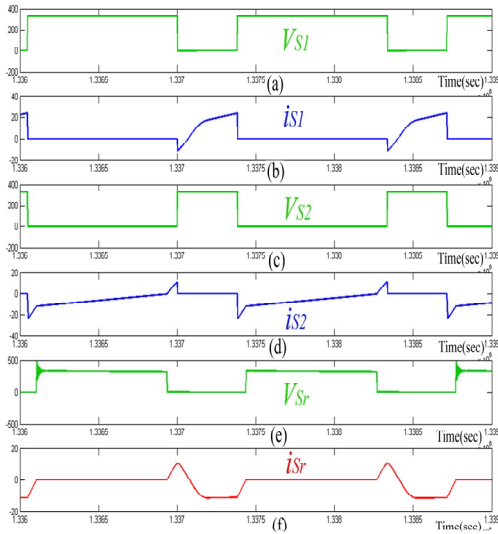

Figure 8. Buck mode Simulated waveforms (a)  $V_{S1}$  (b)  $V_{S2}$  (c)  $i_{S1}$  (d)  $i_{S2}$  (e)  $V_{Sr}$  (f)  $i_{Sr}$

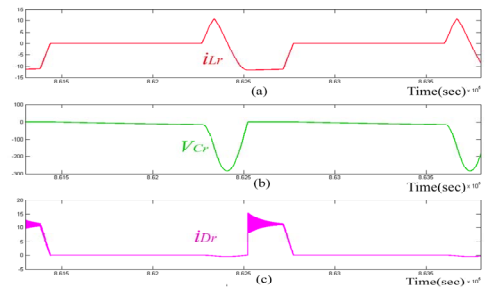

Figure.9 Buck mode Simulated waveforms (a)  $i_{Lr}$  (b)  $V_{Cr}$  (c)  $i_{Dr}$

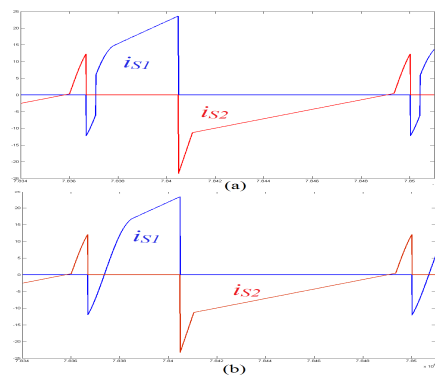

Figure.10. ZVS turn on and ZCS turn off transitions of  $S_1$  and  $S_2$  : (a) When  $S_r$  duty cycle = 0.08 (b) When  $S_r$  duty cycle = 0.12 : Buck mode

#### IV. CONCLUSION

This paper presents a new soft-switching bidirectional converter for energy storage applications. The proposed bidirectional converter obtains soft-switching characteristics for all switches by using simple auxiliary circuit. The ZVS turn on and ZCS turn off conditions are achieved for both boost and buck modes. The simulations are carried out on 100 V-340V converter system operated at 600W output power. This topology will be a suitable candidate for future trends with significant merits such as reduced switching losses, high power and better efficiency.

#### REFERENCES

- [1] H. Do, "Nonisolated Bidirectional Zero-Voltage-Switching DC-DC Converter," IEEE Transactions on Power Electronics, vol. 26, no. 9, pp. 2563-2569, Sept. 2011.
- [2] Y. Zhang, X. Cheng, C. Yin and S. Cheng, "Analysis and Research of a Soft-Switching Bidirectional DC-DC Converter Without Auxiliary Switches," IEEE Transactions on Industrial Electronics, vol. 65, no. 2, pp. 1196-1204, Feb. 2018.
- [3] H. Wu, Y. Lu, L. Chen, P. Xu, X. Xiao and Y. Xing, "High step-up/step-down non-isolated BDC with built-in DC-transformer for energy storage systems," IET Power Electronics, vol. 9, no. 13, pp. 2571-2579, 26 10 2016.
- [4] Liqun Chen, Hongfei Wu, Yan Xing and Xi Xiao, "Performance evaluation of a 1kW non-isolated high step-up/step-down bidirectional converter for distributed battery storage system," 2015 IEEE 2nd International Future Energy Electronics Conference (IFEEEC), Taipei, 2015, pp. 1-5.
- [5] J. Yang and H. Do, "Soft-Switching Bidirectional DC-DC Converter Using a Lossless Active Snubber," IEEE Transactions on Circuits and Systems I: Regular Papers, vol. 61, no. 5, pp. 1588-1596, May 2014.
- [6] J. Yang and H. Do, "High-Efficiency Bidirectional DC-DC Converter With Low Circulating Current and ZVS Characteristic Throughout a Full Range of Loads," IEEE Transactions on Industrial Electronics, vol. 61, no. 7, pp. 3248-3256, July 2014.
- [7] M. R. Mohammadi and H. Farzanehfar, "A New Family of Zero-Voltage-Transition Nonisolated Bidirectional Converters With Simple Auxiliary Circuit," IEEE Transactions on Industrial Electronics, vol. 63, no. 3, pp. 1519-1527, March 2016.
- [8] G. Chen et al., "A Family of Zero-Voltage-Switching Magnetic Coupling Nonisolated Bidirectional DC-DC Converters," IEEE Transactions on Industrial Electronics, vol. 64, no. 8, pp. 6223-6233, Aug. 2017.
- [9] H. Hosseini, Z. Saadatizadeh and P. C. Heris, "A new multiport non-isolated bidirectional dc/dc converter with zero voltage switching and free ripple input currents," 2017 10th International Conference on Electrical and Electronics Engineering (ELECO), Bursa, 2017, pp. 279-284.
- [10] N. Zahedi, S. Salehi and S. H. Hosseini, "Non-Isolated Three Port DC-DC Converter with Soft Switching Technique\*," 2019 10th International Power Electronics, Drive Systems and Technologies Conference (PEDSTC), Shiraz, Iran, 2019, pp. 401-406.
- [11] Y. Jang and M. M. Jovanović, "Soft-switched bidirectional buck-boost converters," 2017 IEEE Applied Power Electronics Conference and Exposition (APEC), Tampa, FL, 2017, pp. 287-293.
- [12] Y. Panov, Y. Jang, M. M. Jovanović and B. T. Irving, "Design optimization and performance evaluation of high-power, high-frequency, bidirectional buck-boost converter with SiC MOSFETs," 2017 IEEE Applied Power Electronics Conference and Exposition (APEC), Tampa, FL, 2017, pp. 259-266.