

New Approach In Designing Hexagonal-Shaped Antenna Based On Area Analysis

Hesam Siahkamari
Department of Electronics and
Information Technology, Faculty of
Electrical Engineering
University of west Bohemia
Pilsen, Czech Republic
hesam@fel.zcu.cz

Maryam Jahanbakhshi
Department of Electronics and
Information Technology, Faculty of
Electrical Engineering
University of west Bohemia
Pilsen, Czech Republic
maryam@fel.zcu.cz

Saeedeh Lotfi
Department of materials and
technology, Faculty of Electrical
Engineering
University of west Bohemia
Pilsen, Czech Republic
Lotfi@fel.zcu.cz

Abstract— In this article, a new method is presented to calculate dimensions of a hexagonal-shaped antenna based on frequency and rectangular-shaped antenna. The frequency responses of the presented antenna are compared with rectangular shape antenna and both antennas are designed at 2.4 GHz. The dimensions of ground are assumed 10×10 mm². The areas of the rectangular and hexagonal-shaped antennas are the same, therefore the frequency of both of them are 2.4 GHz and gain, directivity, and efficiency because of changing structure are improved.

Keywords— Rectangular-Shaped Antenna, Hexagonal-Shaped Antenna, Area, Gain.

I. INTRODUCTION

Microstrip antennas are one of the main devices in developing wireless communication systems, which are one of the most innovative topics in antenna theory. Since, using electrical conductor wires are tough or impractical to implement and also it is costly, thus, the researchers are perusing to focus on this field and try to make design and construction easier. In [1] proposed new fractal ultra-wideband CPW-fed antenna (UWB), the antenna uses a basic hexagonal shape, in which different modifications are made applying concepts of fractal structure and Notch filters to gain the optimal model. In [2] a hexagonal-shaped multiple-input multiple-output patch antenna is simulated and fabricated. It covers the S band (2–4 GHz) and X band (8–12 GHz) applications. A unique concentric hexagonal-shaped ring antenna for radio frequency identification (RFID) is proposed in [3]. The rings are excited with a microstrip feedline. This antenna is working at the UHF band from 800 MHz to 960 MHz. In [4] a novel ultra-wideband fractal monopole antenna is designed and fabricated. In this design authors used trapezoidal shapes with hexagonal slots to achieve highly Ultra-Wideband characteristics. In terms of the resonator designing based on the area analyze, there are some different structures of them which are presented in different papers [5–14]. For instance, in [5] the trapezoid-shaped structure is used for designing the resonators. T-shaped and L-shaped resonators are applied in [6–8] and the authors used triangular and square-shaped structures in [9–11]. Another structures are elliptical and quasi elliptical-shaped, which are used to design resonators in [12–14]. In this paper, a new approach for designing microstrip antennas is presented and a hexagonal-shaped antenna based on frequency and rectangular-shaped structure is designed. The rectangular and hexagonal-shaped structures have the same area and operational frequency is 2.4 GHz for both of them.

II. RECTANGULAR AND HEXAGONAL-SHAPED ANTENNAS

A. rectangular-shaped antennas

A rectangular-shaped antenna is illustrated in Fig. 1, which is designed based on Eq.1 to Eq.5 to calculate its dimensions, [15]. The main parameters of the rectangular-shaped antenna such as; S_{11} , gain, directivity, efficiency and power are shown in Fig. 2a-e, respectively. The width of the rectangular-shaped antenna is calculated by Eq.1 and its length is computed using Eq.5. Where, the ϵ_r is referred to the dielectric constant, h is thickness of the substrate and f_0 is the operational frequency, also ϵ_{eff} is effective dielectric constant. The width and length of the rectangular-shaped antenna are 37.86 mm and 29.1 mm, respectively.

$$W = \frac{c}{2f_0\sqrt{\frac{\epsilon_r+1}{2}}} \quad (1)$$

$$\epsilon_{eff} = \frac{\epsilon_r+1}{2} + \frac{\epsilon_r-1}{2} \left[1 + 12\frac{h}{w}\right]^{-1/2} \quad (2)$$

$$L_{eff} = \frac{c}{2f_0\sqrt{\epsilon_{eff}}} \quad (3)$$

$$\Delta L = 0.412h \frac{(\epsilon_{eff} + 0.3)\left(\frac{w}{h} + 0.264\right)}{(\epsilon_{eff} - 0.258)\left(\frac{w}{h} + 0.8\right)} \quad (4)$$

$$L = L_{eff} - 2\Delta L \quad (5)$$

B. hexagonal-shaped antenna

The area of the rectangular and hexagonal-shaped resonator should be equaled to each other and based on Fig. 3 and Eq.6 the height of triangular (A) can be calculated. In Eq.6, the area of the rectangular-shaped antenna has been equaled with the area of the hexagonal-shaped antenna, [10]. In Eq.6, W and L are the width and length of the rectangular-shaped antenna and the structure of the total hexagonal-shaped antenna is combined of one rectangular-shaped and two triangles-shaped patches on both sides. Thus, W1 and L1 are the width and length of the hexagonal-shaped and A is height of triangles. As a result, in Eq.6, A will be 6 mm and the operational frequency of the new antenna which is shown in Fig.4, is around 2.4 GHz.

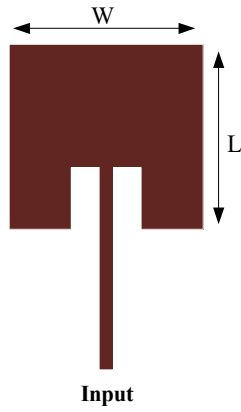
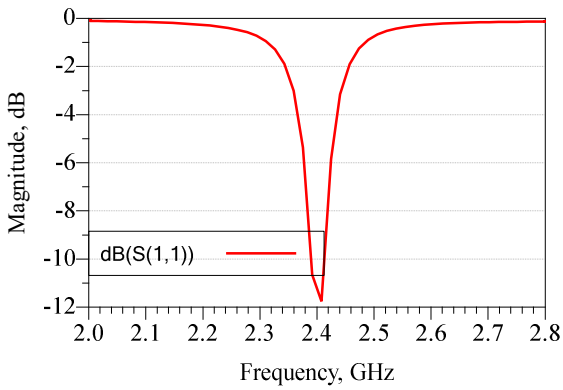
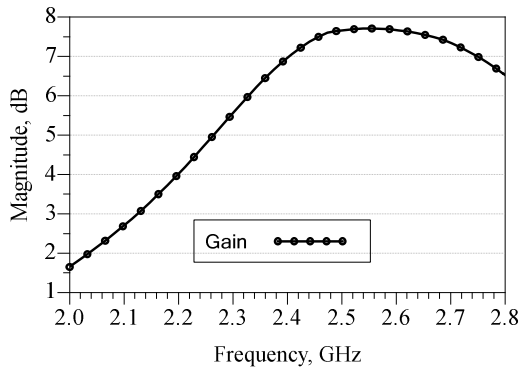

Fig.1 Rectangular-shaped antenna.



(a)



(b)

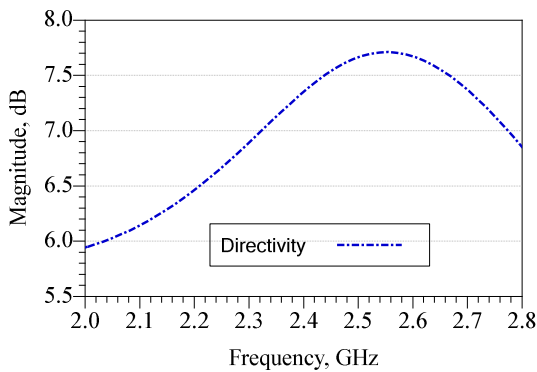

(c)

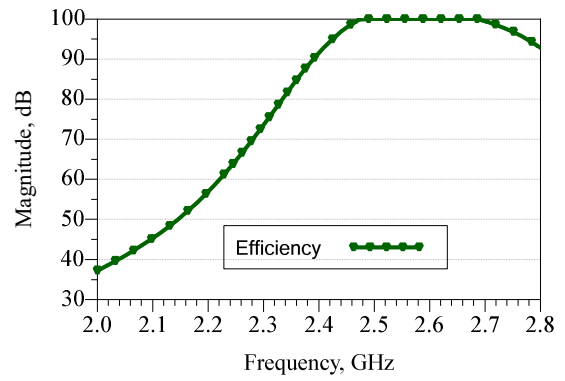

(d)

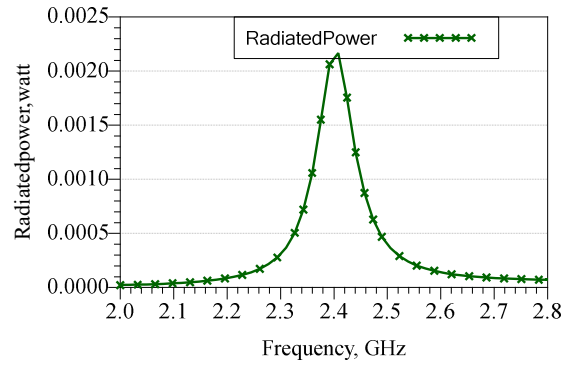

(e)

Fig.2 Frequency response of rectangular-shaped antenna a) S-parameter, b) Gain, c) Directivity, d) Efficiency, e) Radiated power.

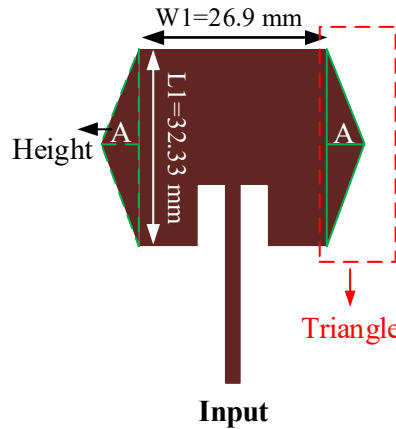

Fig. 3 Hexagonal-shaped antenna.

$$W \times L = W_1 \times L_1 + 2 \left(\frac{A \times W_1}{2} \right) \quad (6)$$

Based on the Eq.6 the dimension of the triangle-shaped patches have been selected based on equalization of the hexagonal and rectangular-shaped antennas' area.

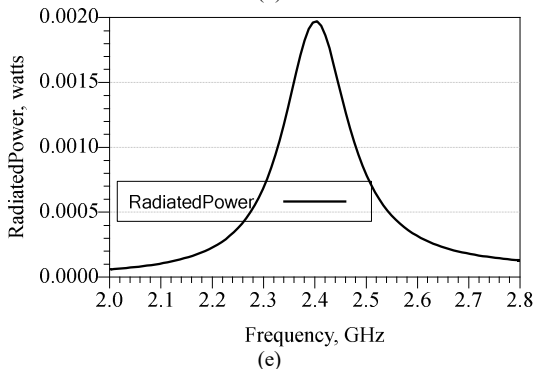
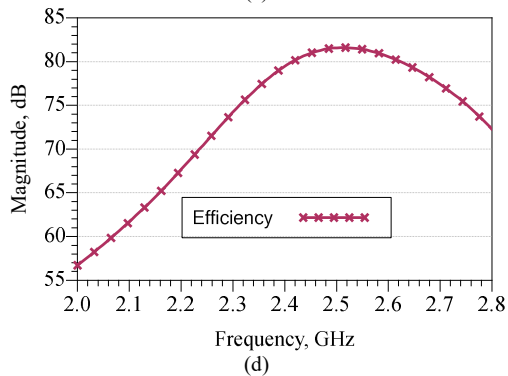
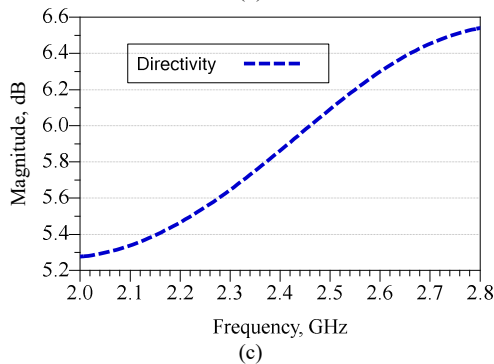
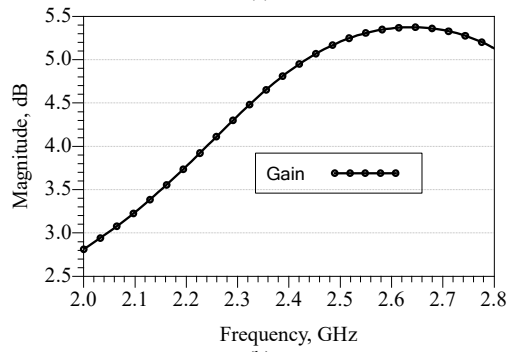
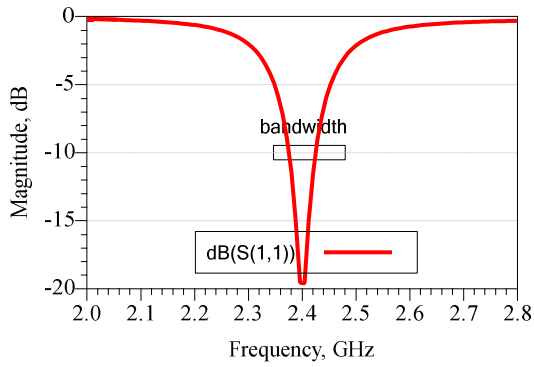

Fig.4 Frequency response of hexagonal-shaped antenna a) S-parameter, b) Gain, c) Directivity, d) Efficiency, e) Radiated power

III. SIMULATION RESULTS:

Both of circuits are simulated on FR4 substrate with thickness of 1.6 mm. The return loss and bandwidth of rectangular-shaped antenna are 11.7 dB and 16 MHz. Moreover, the return loss and bandwidth of hexagonal-shaped antenna are 19.6 dB and 50 MHz, [9] that all parameters are extracted by software (ADS). Directivity and efficiency of the hexagonal shape antenna are shown in Fig.4 (c and d) which directivity is the radiation emitted is concentrated in a single direction and antenna efficiency is how much RF power delivered to the antenna. The S_{11} of the rectangular and hexagonal-shaped antennas are compared in Fig.5 and in Table. 1, both of the antennas are compared with each other.

TABLE I. COMPARISON BETWEEN RECTANGULAR AND HEXAGONAL-SHAPED ANTENNAS

antenna	Return loss (dB)	Bandwidth (MHz)	Gain (dB)	Directivity (dB)	Radiated power (watt)
Rectangular	11.7	16	7.7	7.7	0.002
Hexagonal	19.6	50	5.37	6.5	0.002

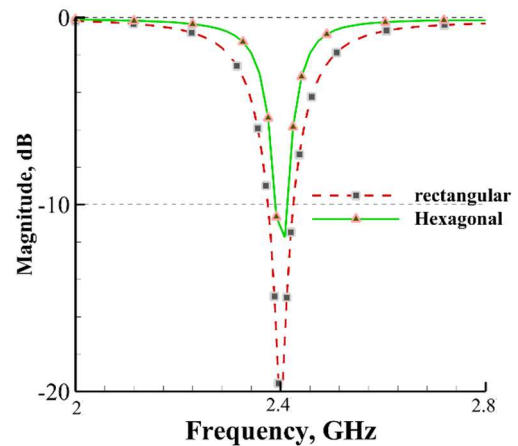

Fig.5 S_{11} parameter for rectangular and hexagonal-shaped antennas.

IV. CONCLUSION

Simulations of the rectangular and hexagonal-shaped antennas are done by an EM-simulator ADS software. The main parameters of both rectangular and hexagonal-shaped antennas are compared and using this method, it can be seen the hexagonal shaped antennas has better performance. The presented method can be used for different shaped and in hexagonal-shaped antenna the return loss and bandwidth parameters are improved and they are 19.6 dB and 50 MHz, but gain and directivity are decreased and based on the application can be used. Furthermore, array methods can be utilized to increase gain and directivity.

REFERENCES

- [1] J. B. Benavides, R. A. Lituma, P. A. Chasi and L. F. Guerrero, "A Novel Modified Hexagonal Shaped Fractal Antenna with Multi Band Notch Characteristics for UWB Applications," 2018 IEEE-APS

Topical Conference on Antennas and Propagation in Wireless Communications (APWC), pp. 830-833, 2018 .

- [2] T. Addepalli, , & V. R. Anitha, "Design and parametric analysis of hexagonal shaped MIMO patch antenna for S-band, WLAN, UWB and X-band applications." *Progress In Electromagnetics Research C*, 97, 227-240. 2019.
- [3] M. Alibakhshikenari, et al. "Novel Concentric Hexagonal-Shaped RFID Tag Antenna With T-Shaped Stub Matching." *IEEE Journal of Radio Frequency Identification*, 6, 112–120. 2022 .
- [4] D. Aissaoui, et al. "CPW - fed UWB hexagonal shaped antenna with additional fractal elements." *Microwave and Optical Technology Letters* 58.10 : 2370-2374. 2016.
- [5] H. Siahkamari, M. Jahanbakhshi, H. Al-Anbagi, A. Abdulhameed, M. Pokorny, & R. Linhart, "Trapezoid-shaped resonators to design compact branch line coupler with harmonic suppression." *AEU-International Journal of Electronics and Communications*, 144, 154032. 2022.
- [6] M. Jahanbakhshi, and M. Hayati, : 'Design of a compact microstrip lowpass filter with sharp roll-off using combined T-shaped and L-shaped resonators. *Electron. Lett.*, 52, (23), pp. 1931-1933, 2016.
- [7] H. Siahkamari, et al. Design of compact Wilkinson power divider with harmonic suppression using T-shaped resonators. *Frequenz*, 72(5-6), 253-259. 2018.
- [8] S. Lotfi, S. Roshani, S. Roshani. Design of a miniaturized planar microstrip Wilkinson power divider with harmonic cancellation. *Turkish Journal of Electrical Engineering and Computer Sciences*. 28(6):3126-36. 2020.
- [9] H. Siahkamari, S. Lotfi, M. Tahmasbi, T. Belecha, R. Linhart, M. Hookari, S. Ahmadi, M. Jahanbakhshi. Design and analysis of a compact and harmonic suppressed microstrip lowpass filter. *International Journal of Engineering & Technology Sciences*, s. 1-12. ISSN: 2289-4152, 2021.
- [10] S. Lotfi, M. Hayati. Compact low-pass filter with ultra-wide stopband using analysed triangular-shaped resonator. *Electronics Letters*. 53(15):1050-2. 2017.
- [11] M. Jamshidi, Lalbakhsh A, Lotfi S, Siahkamari H, Mohamadzade B, Jalilian J. A neuro - based approach to designing a Wilkinson power divider. *International Journal of RF and Microwave Computer - Aided Engineering*. 30(3):e22091. 2020.
- [12] Karimi G, Lotfi S, Siahkamari H. Design of microstrip lowpass filter with sharp roll-off using elliptical and radial resonators. *Frequenz*. 71(7-8):349-56. 2017.
- [13] Hayati M, Lotfi S, Siahkamari H, Blecha T, Linhart R, Jamshidi MB. A compact simple microstrip lowpass filter based on elliptical analyzed resonator. *Frequenz*. 76(5-6):247-54. 2022.
- [14] Wang, J., Xu, L-J., Zhao, S., Guo, Y-X., and Wu, W.: 'Compact quasielliptic microstrip lowpass filter with wide stopband'. *Electron. Lett.*, 46(20), pp. 1384-1385, 2010.
- [15] Hong, J.-S.: 'Microstrip filters for RF/microwave applications' Wiley, New York, USA, 2nd edn. 2011.