

# Evaluation of electrical resistance of electrodes with conductive ink for agriculture applications using computer technology

VIKTOR NOVÁK<sup>1\*</sup>, JAROMÍR VOLF<sup>1</sup>, DANIEL NOVÁK<sup>2</sup>, VÁCLAV VRBÍK<sup>3</sup>,  
VLADIMÍR RYŽENKO<sup>1</sup>, JÁN STEBILA<sup>2</sup>

<sup>1</sup>Department Electrical Engineering and Automation, Czech University of Life Sciences Prague, Prague, Czech Republic

<sup>2</sup>Department of Technology, Matej Bel University, Banská Bystrica, Slovak Republic

<sup>3</sup>Department of Computer Science and Educational Technology, University of West Bohemia, Pilsen, Czech Republic

\*Corresponding author: [novakviktor@tf.czu.cz](mailto:novakviktor@tf.czu.cz)

**Citation:** Novák V., Volf J., Novák D., Vrbík V., Ryženko V., Stebila J. (2022): Evaluation of electrical resistance of electrodes with conductive ink for agriculture applications using computer technology. Res. Agr. Eng., 68: 194–200.

**Abstract:** The article presents the ongoing research, which aims to select suitable electrodes and mixtures of conductive inks, which will be used as a converter between the pressure and electrical quantities in the design of planar pressure transducers. In the described research, we continue our previous work and the work of other authors who have previously dealt with the properties of conductive inks and electrodes. Due to the only partial results in the given field, we decided to perform an extensive and original measurement of a total of 172 combinations of different electrode sizes, various conductive ink mixtures and ink layer thicknesses. Thanks to this, it will be possible, in the future, to select a suitable combination of electrodes and inks when designing pressure sensors for industrial and agricultural applications without the need to perform time-consuming preparatory measurements. The aim of the measurements is also to determine the usable working range of the pressures and the corresponding sensitivity for certain combinations of electrodes and inks, and to also exclude those variants which are unsuitable for the given purposes. This paper presents the introductory part of the measurements, which aims to verify the methodology of the measurements on a test plate at robotised workspace that is connected to a PC in real time via the program LabView. The described introductory measurements proved our methodology to be suitable to the given purpose; however, there minor problems emerged with the actual working pressure range of the transducer and the consequential necessary adjustments of the control program.

**Keywords:** conductive ink; electrode; LabView; pressure; tactile sensor; tyre

In agriculture, it is very important to evaluate the pressures exerted by agricultural machinery on the soil. When inappropriate tyre inflation is used, significant soil compaction occurs, which damages the properties of the topsoil in the field. This may occur, for example, due to overinflated tyres or their improper inflation with respect to the moisture and

soil bearing capacity or to the weight of the used agricultural machinery. Conversely, underinflated tyres on roads cause a significant impact on the fuel consumption. This dependence can then be determined for different tyre profiles or tyre manufacturers, see more in Bílek et al. (2012). If we know these characteristics, they can be entered into the control

Supported by the Technology Agency of the Czech Republic, Project No. FW01010217.

<https://doi.org/10.17221/60/2021-RAE>

systems of the agricultural machinery and, thus, the optimal tyre pressure can be set automatically for the immediate soil and weather conditions. In this way, soil compaction can be prevented or fuel consumption can be reduced. Beside the main considered use transducers in agricultural applications, they can be potentially used in other branches of industry, e.g., in the automotive industry, in the design of ergonomically shaped furniture or in medicine.

In our previous work, we developed the planar measuring system PLANTOGRAF that evaluates the pressure distribution between the road, the soil and the tyre, or even within the soil itself. Its current version consists of 16 400 individual sensors that change their electrical resistance due to the applied pressure, whose predecessors also used individual electrodes to convert the pressure into electric signals, however, they used a different technology (originally conductive rubber, further conductive ink on a separate foil layer), for more detailed information about the previous research, see, e.g., Volf et al. (2015, 2019) and Koder et al. (2018). The main difference represents another method of applying ink to the electrodes and the flexibility of the transducer; any individual sensor represents a circle electrode with conductive ink applied directly to it, unlike previous solutions, where the ink was applied on a separate layer, for more discussion on this, see Volf et al. (2019). This was possible using a different ink type, namely a polymer-based one instead of a water-based one that did not adhere to the electrode. The principle of the transducer is similar to that in a microphone: as pressure is applied, the microscopic conductive particles in the transducer approach one another and this causes a decrease in the measured resistivity of the material. When pressure is applied, the material of the transducer is deformed and its electrical resistivity changes. The value of the resistivity is subsequently used to compute the pressure.

The planar transducer originally came with a conductive rubber-based ink on the experiences of Barman and Guha (2006) and Souza et al. (2005). Within our research, we also reflect the newer experiences of teams experimenting with piezoresistive materials, e.g., by the design of Force Sensitive Resistor (FSR) sensors by Giovanelli and Farella (2016) with a lower pressure range. A similar solution using printing technology used in robotics is described by Seo et al. (2016), however, they only produced a binary output signal which was not usable for our requirements. Another flexible pressure sensor was being developed

by Maddipatla et al. (2017), they have used different technology (capacitive sensor) showing promising results, however, its sensitivity would be not sufficient for our purposes. Another interesting solution using a paper-based piezoresistive pressure sensor was described by Gao et al. (2019), however, this technology has limitations due to the possible mechanical wear of the material. The properties of conductive inks have extensively been described by Dimitriou and Michailidis (2021). The authors also focused on the electrical conductivity of conductive inks, that we will also reflect on in further parts of our research, where different ink mixtures will be evaluated. The original methodology and results of our research team are described in Volf et al. (2019), we continue the new measurements with a slightly modified methodology as described further.

Within our article, we aim to acquaint the reader with the issue of piezoresistive transducers in general, and specifically with the proposed methodology of the measurement of the electrical resistance of the ink layer. This measurement will precede the extensive measurement of all 172 combinations of the different electrode sizes, the ratios of the conductive ink mixture and the thicknesses of the applied ink layer. The main goal of our work is to demonstrate and to discuss the suitability of the proposed methodology, based on the results of this introductory measurement. We also aim to preliminarily determine the usable working range of the pressures and the corresponding sensitivity for certain combinations of electrodes and inks, and to also exclude those variants which are unsuitable for the given purposes.

## MATERIAL AND METHODS

As we started the development of the new transducer, we ordered, at the Faculty of Chemical Technology, the University of Pardubice, individual samples, see the sample in Figure 1. These samples were made using printing technology. Each one includes 18 individual circular electrodes with the different dimensions stated in Table 1; the corresponding dimensions are graphically explained in Figure 2.

Any of the nine samples will have a different combination of the factors that may influence the sensitivity of the sensor, namely:

- thickness of the ink layer
- proportion of two conductive inks in the mixture
- dimensions of the electrode

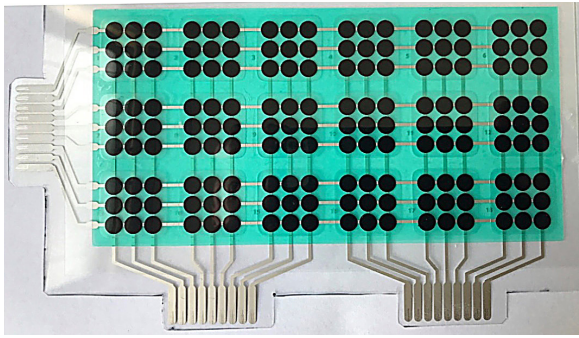

Figure 1. Sample with circular electrodes

Before we received the complete set of the nine samples, we obtained a “pre-sample plate” to evaluate the design and the suitability for the further measurements of the full sample set. This “pre-sample” has an ink layer thickness of  $25 (\pm 1) \mu\text{m}$  and it uses the inks Henkel NCI 7002 and ECI 7004HR with a ratio of 60:40 in the mixture. We will describe the methodology and the results of this preliminary measurement and we will define the possible necessary adaptations of the future measurement of the full set.

Due to the proposed extended 172 ink-electrode combinations, we decided to perform the measure-

ments as automatically as possible. This included four key parts, namely using a robotised arm to extend the selected force on the electrode, a control program to set the pressure automatically, an electric circuit to determinate the electrical resistance as the output variable and the LabView program (Ver. 2016; 2016) to collect the data and calculate the quantities.

The measurements of the dependency of the output voltage (or else electrical resistance) were performed at a robotised workplace equipped with a Turbo Scara SR60 (Bosch, Germany) robot. The basic step of the vertical motion of the robot’s arm is 0.01 mm. Pressure was applied by the 3 mm in diameter measuring tip by means of the vertical motion of the robot’s arm. The arm was moved in 0.02 mm increments for a general overview of the behaviour of an electrode and further in 0.01 mm steps for a more detailed analysis; this more detailed course was only measured on some selected (the most convenient) electrodes and will be presented later. The loading force was exerted from 0.37 N up to cca. 17.6 N. The pressure applied on the electrodes was calculated from the known area of the surface of the measuring tip and the exerted force. This resulted in a measured range of pressure values from approx. 30 up to 1 400 kPa for the particular measuring tip.

The measuring tip was fixed to a Hottinger DF2S-3 (Hottinger Baldwin Messtechnik, Germany) load cell at the end of the robot’s arm. This load cell was chosen due to its high sensitivity and appropriate range. The control unit is set to display the values in grams; the conversion into pressure values was subsequently performed in the PC program. The measuring pressed with a defined force against a selected electrode via which the electric

Table 1. Dimensions of the electrodes

No.	$R_1$	$R_2$	$R_3$	$R_4$	E	M
1	0.2	0.45	0.55	1	2	0.1
2	0.05	0.45	0.55	1	2	0.1
3	0.2	0.5	0.75	1.25	2.5	0.25
4	0.05	0.5	0.75	1.25	2.5	0.25
5	0.05	0.825	0.925	1.75	3.5	0.1
6	0.05	0.8	0.95	1.75	3.5	0.15
7	0.05	0.775	0.975	1.75	3.5	0.2
8	0.05	0.75	1	1.75	3.5	0.25
9	0.05	0.725	1.025	1.75	3.5	0.3
10	0.05	0.7	1.05	1.75	3.5	0.35
11	0.05	0.675	1.075	1.75	3.5	0.4
12	0.05	0.75	0.85	1.6	3.2	0.1
13	0.05	0.725	0.875	1.6	3.2	0.15
14	0.05	0.7	0.9	1.6	3.2	0.2
15	0.05	0.675	0.925	1.6	3.2	0.25
16	0.05	0.65	0.95	1.6	3.2	0.3
17	0.05	0.625	0.975	1.6	3.2	0.35
18	0.05	0.6	1	1.6	3.2	0.4

$R_1$ – $R_4$  – radii; E – outer diameter; M – gap between the inner and outer electrode

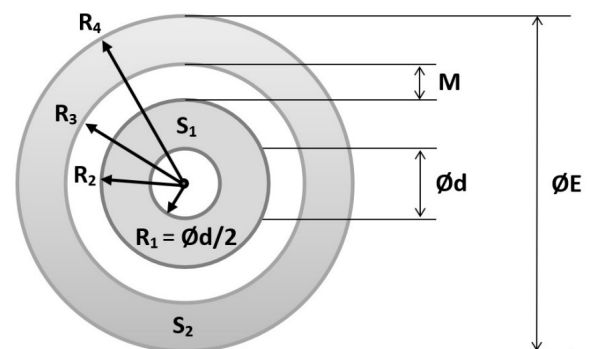

Figure 2. Dimensions of the electrodes

<https://doi.org/10.17221/60/2021-RAE>

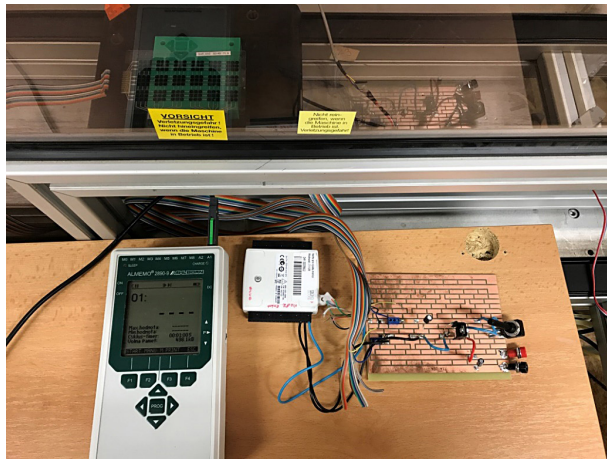

Figure 3. Robotised measuring workspace

resistance of the material was measured. The output voltage was measured by an Almemo 2890-9 Data Logger (Ahlborn GmbH, Germany). The measured data from both sources (force and voltage) were sent to the PC in real time, where they were subsequently processed using the software LabView. The measuring robotised workspace with the connected buses to the voltage stabiliser with the data logger is depicted in Figure 3, the connected sample plate is placed in the screened robot working area in the back.

The circuit diagram to determine the electrical resistance of the ink is depicted in Figure 4. It consists of a stabilised circuit that supplies a voltage divider, wherein one resistor is constant and the other one, represented by the resistance of the conductive ink ( $R_{ink}$ ), is variable.

The electrical resistance of a particular electrode depends on several variables, namely on the dimension of the used electrode, on the used ink or ink

mixture and on the thickness of the applied ink layer. Within this introductory measurement, we kept the ink mixture and ink layer constant, we only checked the various electrode dimensions. Theoretically, the measured electrical resistance of an electrode should decrease with its size, as more conductive paths within the ink are created, and it should also decrease with a smaller gap between the inner and outer electrode.

The sensitivity of an electrode is generally determined as  $\Delta R/\Delta p$ ; as the dependency between the applied pressure and the electrical resistance is not linear, the sensitivity must be determined experimentally and separately for any individual electrode. Then, it can be calculated as the direction of the tangent at any individual point.

## RESULTS AND DISCUSSION

The above-described measurement was repeated for each electrode seven times to enable some basic statistical evaluation of the results. We graphically present the measurement results for 10 out of selected 18 electrodes; some courses were very similar, so it is not necessary to present the almost identical courses; we rather want to point out the particularity of each course and shortly discuss it. The following graphs show the dependency of the electrical resistance (in  $k\Omega$ ) on the applied pressure (in  $kPa$ ) in the range from cca. 100  $kPa$  to the maximal load which was limited to 1 400  $kPa$  by the maximal exerted force. The initial loading pressure varies significantly, as every electrode has its own threshold, when it starts to react to the applied pressure (i.e., when the resistance starts to drop). The scale on the graphs were maintained the same to enable the visual comparison of the courses.

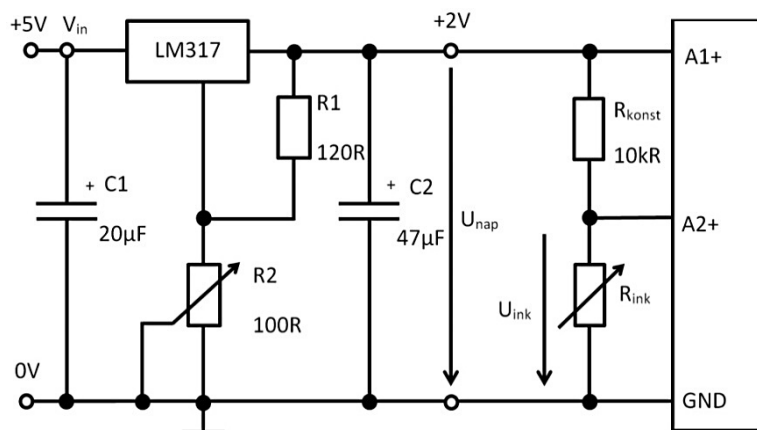

Figure 4. Circuit diagram of the measuring circuit



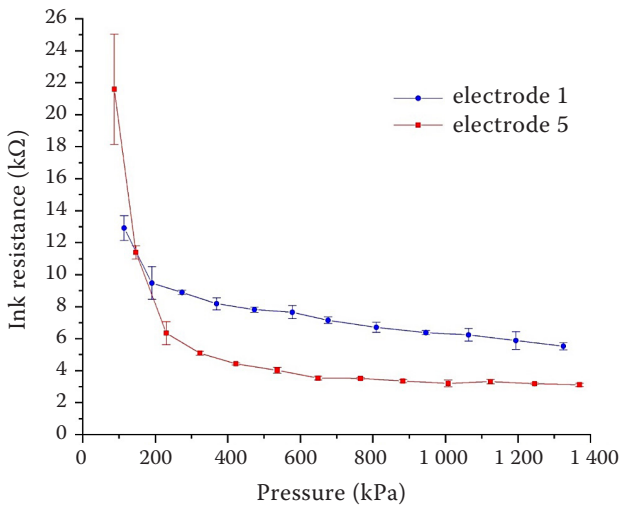

Figure 5. Resistance-pressure characteristic of electrodes No. 1 and No. 5

The course of electrode No. 1 (Figure 5) is very particular compared to the other electrodes. It does not have such a steep initial decrease in the electrical resistance and, after the turn, the resistance falls steeper and almost linear. This course may be very convenient, unfortunately, as there was a lack of data at the beginning. Therefore, it is a candidate to provide a more detailed measurement of the course. Electrode No. 5 exhibits the typical course as demonstrated by most of the electrodes – an initial steep descent in the resistance, then the turn and following a little loss in the resistance with stagnation towards the end.

The depicted electrodes No. 6 and No. 7 (Figure 6) exhibit the typical behaviour described above by the

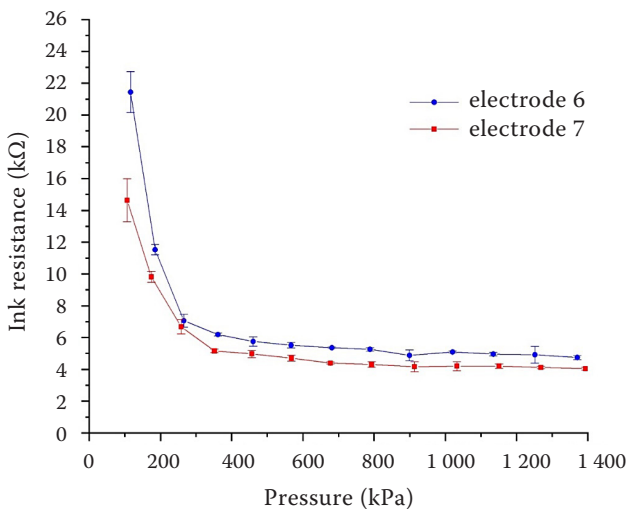

Figure 6. Resistance-pressure characteristic of electrodes No. 6 and No. 7

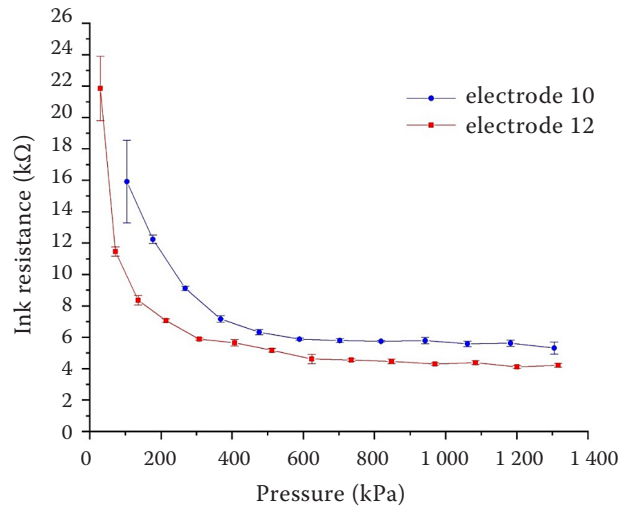

Figure 7. Resistance-pressure characteristic of electrodes No. 10 and No. 12

electrode No. 5; all these electrodes have similar dimensions as stated by the Table 1.

Electrode No. 10 (Figure 7) has a gradual decrease in the resistance up to cca. 400 kPa, followed by stagnation. Also, there is lack of data at the beginning loaded by a significant uncertainty. This electrode may also be a candidate for further measurements. Electrode No. 12 exhibits the typical course, it is notable that its construction enabled the measurement starting at cca. 50 kPa.

Electrode No. 15 (Figure 8) exhibits similar behaviour to electrode No. 10, the measurement is loaded with significantly less uncertainty and starts at lower pressures. Electrode No. 14 has a typical course, its

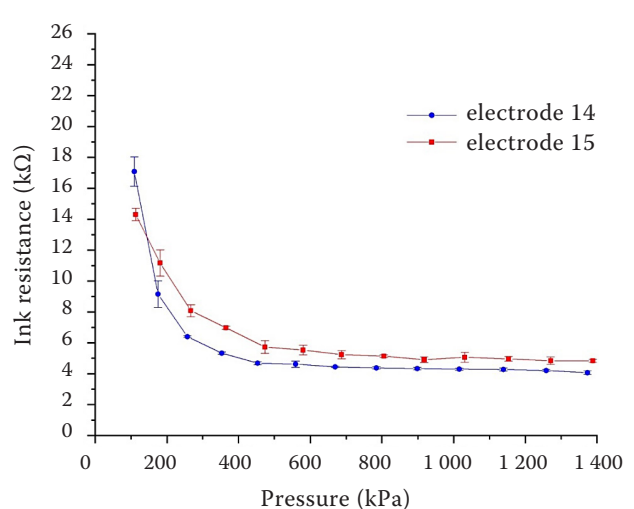

Figure 8. Resistance-pressure characteristic of electrodes No. 14 and No. 15

<https://doi.org/10.17221/60/2021-RAE>

dimensions do not differ significantly from the others. Both electrodes exhibit similar behaviour. They have an initial steep decrease in the resistance, followed by a less sharp turn compared to the other electrodes. However, the stagnation follows immediately (or even with a slight increase in the resistance, but this may be a measuring error given the higher uncertainties). The courses are convenient for measuring lower pressure ranges. Also note the similar dimensions of both electrodes.

In general, every electrode exhibits an initial steep decrease in the electrical resistance followed with a turn, when the resistance decreases significantly with the increasing pressure. This turn is situated in the pressure range 200–400 kPa, depending on the electrode, also the turn is differently sharp. This phenomenon is caused due to the exponential dependency of the resistance on the pressure, which is based on the composition of the material; as the pressure is high enough, significantly less conductive paths are created, thus the resistance decreases only a little.

Furthermore, the uncertainties are generally much greater in the range of the lower pressures, particularly in pressure ranges under the described turn. This is given firstly by the light contact of the measuring tip with the surface and secondly by the light contact of the conductive layer itself with the electrode.

Most electrodes also exhibit stagnation in the loss of electrical resistance towards high pressure levels. This is caused due the saturation of the material, as the particles are compressed to their maximum, so the electrical resistance cannot drop anymore. The usable range of the electrodes is, therefore, limited to pressure ranges below the saturation level.

The particularity of electrode No. 1 was probably caused due to its different dimensions compared to the other electrodes. After verifying the course with more detailed measurements, it may be a suitable electrode for measuring higher pressure ranges due to its almost linear characteristics and better sensitivity in higher pressure ranges.

We can also preliminarily assessed the impact of the electrode size on the measured electrical resistance. It can be demonstrated, e.g., in the graph in Figure 5, with electrodes No. 1 and 5. Here, parameter  $M$  (the gap between the inner and outer electrode) is the same, but the electrical resistance of electrode No. 5 is lower. The key parameter is the dimension of the ring  $R_2$ . The larger  $R_2$  radius enables the formation of more conductive paths within the ink and, thus, decreases the measured electrical

resistance of electrode No. 5. The precise statistical assessment of the impact of the parameters  $M$  and  $R$  on the electrical resistance will be subject of further research.

From the courses of the resistance, it can be seen that the electrodes are not “universal”, i.e., usable in the whole pressure range (with the exception of electrode No. 1). Also, the upper value of the pressure is limited to cca 500 kPa, then the drop in resistance is negligible. However, this does not pose a problem, as such high pressures are not expected to be measured in common industrial or agricultural applications.

## CONCLUSION

The goal of this preliminary research, namely to verify the suitability of the measuring procedure using a test plate, was achieved. The performed measuring methodology and computer processing of the data are suitable, however, to measure the full set of samples, some minor adjustments need to be made.

First, more focus must be given to the lower pressure ranges up to cca. 500 kPa, hence, the electrical resistance does not change significantly with higher pressures, given the saturation of the material. For more detailed measurements, a smaller step (0.01 mm) may be considered for some electrodes, to determine the course more accurately; this applies particularly for low pressure loads (below 200 kPa). The control program of the robot will have to be adjusted accordingly. The dimensions of the electrodes have a partial impact on the course of the resistance-pressure curve, which corresponds the theoretical basis, a more detailed evaluation including different inks will be subject of further research. To facilitate further measurements, which will be quite extensive (9 samples  $\times$  18 electrodes), some minor adjustments of the LabView control program will be also necessary.

In any case, the new design of the electrodes proved to be capable for the proposed use in foil transducers between the pressure and electrical resistance, the main concern is now the usable pressure range.

## REFERENCES

- Barman S., Guha S.K. (2006): Analysis of a new combined stretch and pressure sensor for internal nodule palpation. *Sensors and Actuators A: Physical*, 125: 210–216.

<https://doi.org/10.17221/60/2021-RAE>

- Bílek J., Neuberger P., Volf J., Prikner P. (2012): Determination size of tire contact area on a hard surface by the electronic pressure sensor. *Agritech Science*, 2: 1–4. (in Czech)
- Dimitriou E., Michailidis N. (2021): Printable conductive inks used for the fabrication of electronics: An overview. *Nanotechnology*, 32: 502009.
- Gao L., Zhu C., Li L., Zhang C., Liu J., Yu H., Huang W. (2019): All paper-based flexible and wearable piezoresistive pressure sensor. *ACS Applied Materials and Interfaces*, 11: 25034–25042.
- Giovanelli D., Farella E. (2016): Force sensing resistor and evaluation of technology for wearable body pressure sensing. *Journal of Sensors*, 2016: 9391850.
- Koder P., Novak V., Ryzhenko V., Hruby D., Volf J., Novak D. (2018): Plantograf V18 – New construction and properties. *Agronomy Research*, 16 (Special issue 1): 1085–1094.
- Maddipatla D., Narakathu B., Ali M., Chlahawi A., Atashbar M. (2017): Development of a novel carbon nanotube based printed and flexible pressure sensor. In: 12<sup>th</sup> IEEE Sensors Applications Symposium. Glassboro, March 13–15, 2017: 7894034.
- Seo S., Kim S., Jung J., Ma R., Baik S., Moon H. (2016): Flexible touch sensors made of two layers of printed conductive flexible adhesives. *Sensors*, 16: 1515.
- Souza F.G., Michel R.C., Soares B.G. (2005): A methodology for studying the dependence of electrical resistivity with pressure in conducting composites. *Polymer Testing*, 24: 998–1004.
- Volf J., Svatos J., Koder P., Novak V., Papezova S., Ryzhenko V., Hurtecak J. (2015): Pressure distribution measurement system PLANTOGRAF V12 and its electrodes configuration. *Agronomy Research*, 13: 732–738.
- Volf J., Novak D., Novak V., Papezova S. (2019): Evaluation of foil transducers and their use in tactile sensors. *Measurement*, 136: 573–578.

Received: August 6, 2021

Accepted: March 10, 2022

Published online: November 16, 2022